

[Cameras](#) > [Camera Models](#) > [Basler ace GigE](#) > [acA1300-30gm](#)

# acA1300-30gm

The acA1300-30gm [Basler ace GigE camera](#) with a Sony ICX445 mono CCD sensor delivers 30 frames per second at 1.3 MP resolution.



## In this topic

- [Specifications](#)
  - [General Specifications](#)
  - [Spectral Response](#)
  - [Mechanical Specifications](#)
    - [Camera Dimensions and Mounting Points](#)
    - [Maximum Allowed Lens Intrusion](#)
    - [Stress Test Results](#)
- [Requirements](#)
  - [Environmental Requirements](#)
    - [Temperature and Humidity](#)
    - [Heat Dissipation](#)
  - [Electrical Requirements](#)
    - [Camera Power](#)
    - [Opto-Coupled I/O Input Line](#)
    - [Opto-Coupled I/O Output Line](#)
  - [Circuit Diagrams](#)
  - [Cable Requirements](#)
    - [Ethernet Cable](#)
    - [I/O Cable](#)
- [Physical Interface](#)
  - [Camera Connectors](#)
  - [Connector Pin Numbering and Assignments](#)
- [Precautions](#)
- [Installation](#)
- [Features](#)

## Specifications

## General Specifications

Specification	acA1300-30gm
Resolution (H x V Pixels)	1296 x 966
Sensor Type	Sony ICX445AL Progressive scan CCD Global shutter
Optical Size	1/3"
Effective Sensor Diagonal	6.1 mm
Pixel Size (H x V)	3.75 $\mu\text{m}$ x 3.75 $\mu\text{m}$
Frame Rate (at Default Settings)	30 fps
Product Line	<a href="#">ace classic</a>
Mono / Color	Mono
Image Data Interface	Fast Ethernet (100 Mbit/s) Gigabit Ethernet (1000 Mbit/s)
Pixel Formats	See <a href="#">Pixel Format</a> .
Synchronization	Via hardware trigger Via software trigger Via free run
Exposure Time Control	Via hardware trigger or programmable via the camera API
Camera Power Requirements	Power over Ethernet (PoE) 802.3af compliant supplied via Ethernet connector 12 VDC supplied via I/O connector
	$\approx$ 2.7 W when using Power over Ethernet $\approx$ 2.2 W @ 12 VDC when supplied via I/O connector
I/O Lines	1 <a href="#">opto-coupled input line</a> 1 <a href="#">opto-coupled output line</a>

Lens Mount	C-mount, CS-mount
Size (L x W x H)	42.0 mm x 29 mm x 29 mm (without lens mount or connectors) 60.3 mm x 29 mm x 29 mm (with lens mount and connectors)
Weight	<90 g
Conformity	CE (includes RoHS), UL Listed, FCC, GenICam, GigE Vision, IP30, IEEE 802.3af (PoE), REACH The EU Declaration of Conformity is available on the <a href="#">Basler website</a>
Software	<a href="#">Basler pylon Camera Software Suite</a> (version 4.0 or higher) Available for Windows, Linux x86, Linux ARM, and OS X
Accessories	<a href="#">Cables for your camera model</a> <a href="#">Lenses for your camera model</a> <a href="#">Additional accessories for your camera model</a>

## Spectral Response

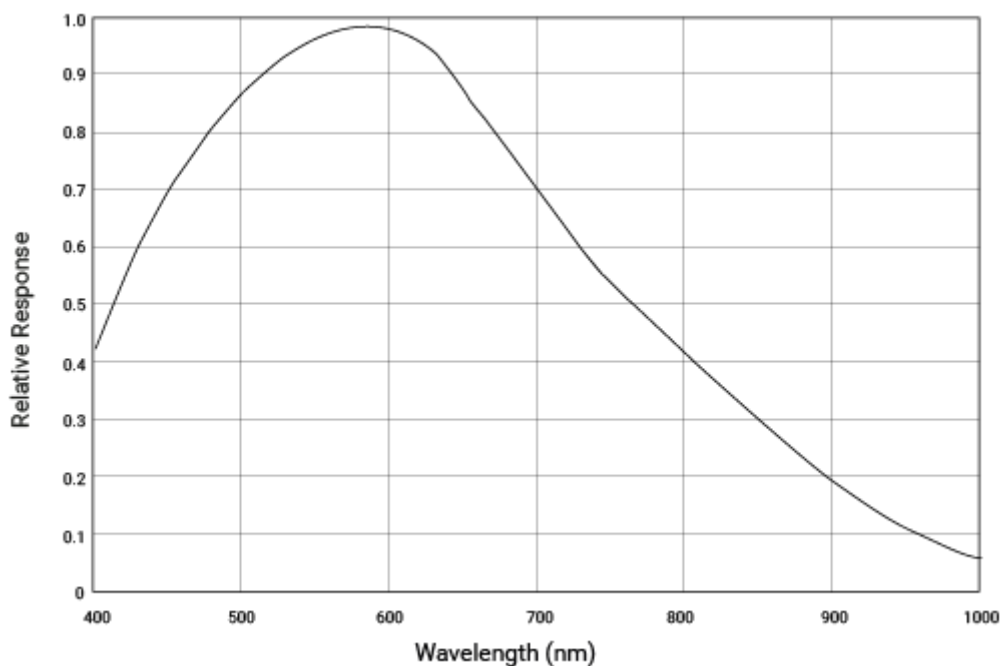

The spectral response curve excludes lens characteristics and light source characteristics.

## Mechanical Specifications

### Camera Dimensions and Mounting Points

### C-Mount Camera Models

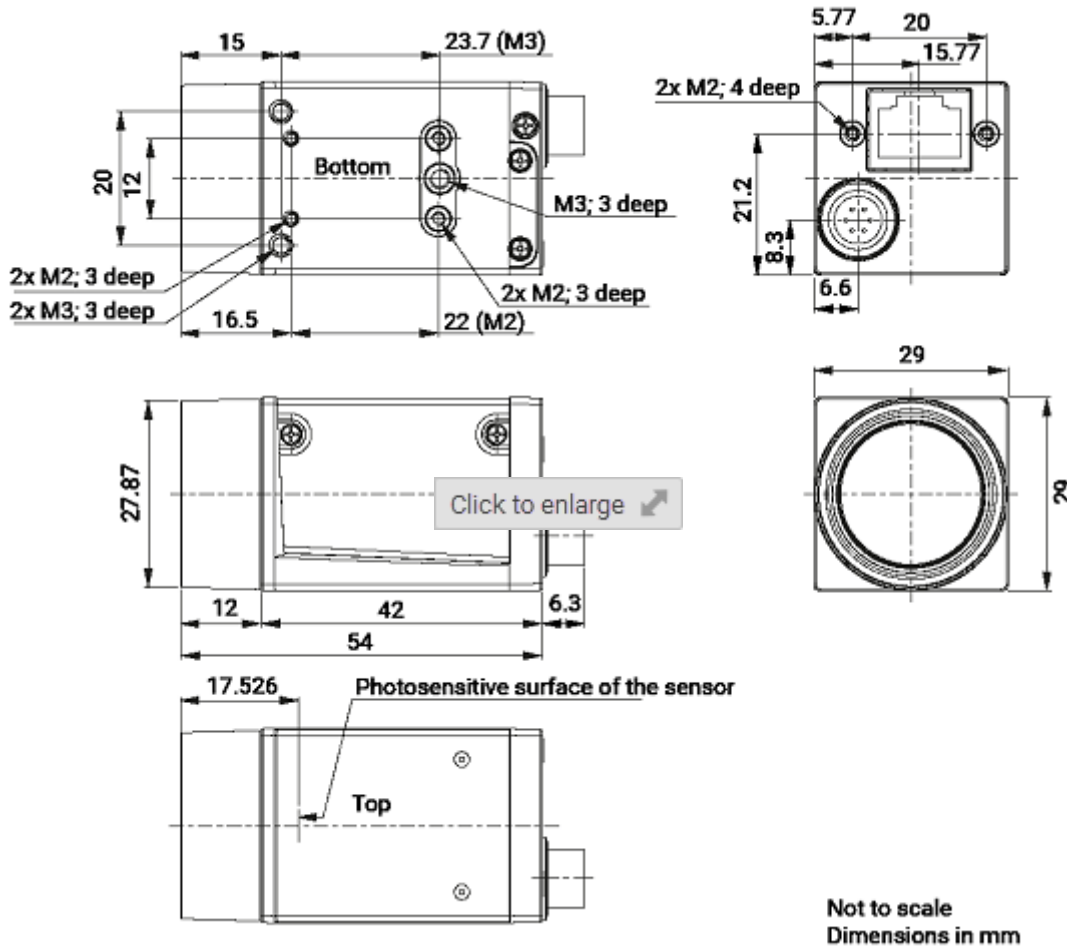

### CS-Mount Camera Models

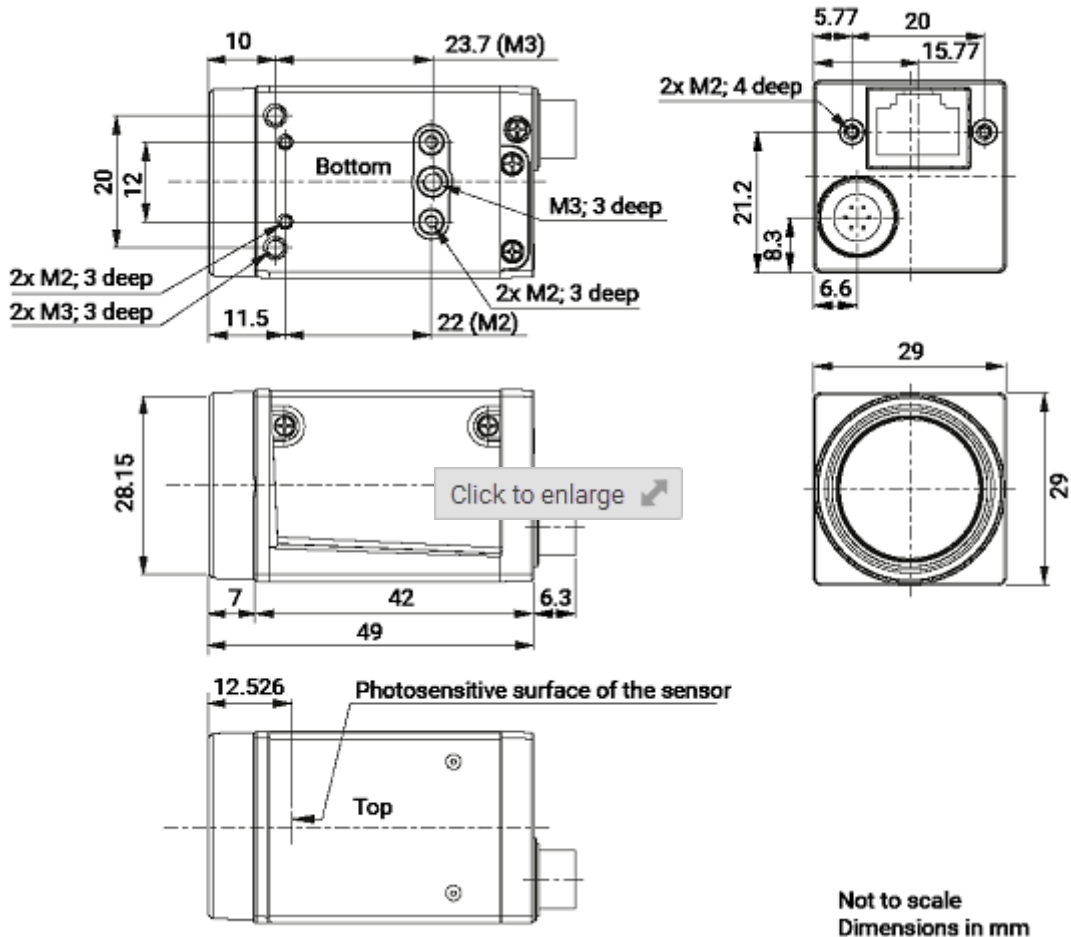

### Maximum Allowed Lens Intrusion

→ See [Maximum Allowed Lens Intrusion](#).

### Stress Test Results

→ See [Stress Test Results](#).

## Requirements

### Environmental Requirements

#### Temperature and Humidity

Housing temperature during operation	0–50 °C (32–122 °F)
Humidity during operation	20–80 %, relative, non-condensing
Storage temperature	-20–80 °C (-4–176 °F)
Storage humidity	20–80 %, relative, non-condensing
Housing temperature according to UL 60950-1	max. 70 °C (158 °F)
Ambient temperature according to UL 60950-1	max. 30 °C (86 °F)

UL 60950-1 test conditions: no lens attached to camera; no heat dissipation measures; ambient temperature kept at 30 °C (86 °F).

## Heat Dissipation

→ See [Providing Heat Dissipation](#).

## Electrical Requirements

### DANGER

#### Electric Shock Hazard



Unapproved power supplies may cause electric shock. Serious injury or death may occur.

- You must use power supplies that meet the Safety Extra Low Voltage (SELV) and Limited Power Source (LPS) requirements.
- If you use a powered hub or powered switch, they must meet the SELV and LPS requirements.

### WARNING

#### Fire Hazard



Unapproved power supplies may cause fire and burns.

- You must use power supplies that meet the Limited Power Source (LPS) requirements.
- If you use a powered hub or powered switch, they must meet the LPS requirements.

### NOTICE

#### Incorrect voltage can damage the camera.

- You must supply camera and I/O power within the safe operating voltage ranges specified below.
- Do not use negative voltage for an I/O line.

## Camera Power

### NOTICE

#### Dual camera power supply can damage the camera.

You must supply camera power **either** via Power over Ethernet (PoE) **or** via the camera's I/O connector. Do not use both ways of supplying camera power at the same time.

- **Power supply via Power over Ethernet (PoE):** Power must comply with the IEEE 802.3af specification.
- **Power supply via I/O connector:** The nominal operating voltage is 12 VDC (10.8 VDC minimum, 13.2 VDC maximum), includes <1 % ripple.

## Opto-Coupled I/O Input Line

Voltage	Description
30 VDC	Absolute maximum. This voltage must never be exceeded. Doing so may damage the camera and voids the warranty.
0–24 VDC	Safe operating range.
0–1.4 VDC	Indicates a logical 0 (with inverter disabled).
>1.4–2.2 VDC	Region where the logic level transition occurs; the logical state is not defined in this region.
>2.2 VDC	Indicates a logical 1 (with inverter disabled).
<ul style="list-style-type: none"> <li>• <b>Minimum current:</b> 5 mA</li> <li>• <b>Current draw:</b> 5–15 mA</li> <li>• If the camera is connected to a PLC device, Basler recommends using a cable that adjusts the voltage level of the PLC to that of the camera.</li> </ul>	

## Opto-Coupled I/O Output Line

Voltage	Description
30 VDC	Absolute maximum. This voltage must never be exceeded. Doing so may damage the camera and voids the warranty.
3.3–24 VDC	Safe operating range.
<3.3 VDC	Unreliable I/O output.
<ul style="list-style-type: none"> <li>• <b>Leakage current:</b> &lt;60 <math>\mu</math>A. Actual leakage depends on operating temperature and production spread of electronic components.</li> <li>• <b>Maximum load current:</b> 50 mA</li> <li>• <b>Minimum load current:</b> Not specified. However, consider the following: <ul style="list-style-type: none"> <li>• Leakage current will have a stronger effect when load currents are low.</li> <li>• Propagation delay of the output increases as load currents decrease.</li> <li>• Higher-impedance circuits tend to be more susceptible to EMI.</li> <li>• Higher currents cause higher voltage drops in long cables.</li> </ul> </li> </ul>	

# Circuit Diagrams

→ See [Circuit Diagrams for Basler ace Cameras](#).

## Cable Requirements

### Ethernet Cable

- Use a high-quality Ethernet cable. Use of shielded CAT 5E or better cables with S/STP shielding is recommended.
- Use either a straight-through (patch) or a cross-over Ethernet cable.
- As a general rule, applications with longer cables or applications in harsh EMI conditions require higher category cables.
- Close proximity to strong magnetic fields should be avoided.
- Basler recommends using Ethernet cables from the [Basler Vision Components](#) range.

### I/O Cable

- The I/O cable must be shielded.
- The I/O cable must have a cross-section of at least 0.14 mm<sup>2</sup> (close to AWG26).
- Use a twisted pair wire cable.
- Maximum recommended cable length: 10 m
- Camera-side connector: Hirose micro plug (part number HR10A-7P-6S) or equivalent
- Close proximity to strong magnetic fields should be avoided.
- If you are supplying power to the camera via Power over Ethernet, the I/O cable will not be used to supply power. However, you can still use the cable to connect to the I/O lines.
- Basler recommends using I/O cables from the [Basler Vision Components](#) range:
  - [Opto-I/O cable, 10 m](#) (blue cable): For use with the [opto-coupled I/O lines](#) of your camera. Does not provide camera power. Therefore, when using this cable, you must provide power via Power over Ethernet (PoE).
  - [Power-I/O cable, 10 m](#) (gray cable): For use with the [opto-coupled I/O lines](#) of your camera. Unlike the opto-I/O cable (blue cable, see above), this cable provides camera power.
  - [Opto-GPIO Y-cable, 2 x 10 m](#) (yellow-blue cable): Offers two separate wires. One can be used to connect the [opto-coupled I/O lines](#) of your camera. The other one can be used to provide camera power.
  - [Power-I/O PLC+ cable, 10 m](#) (gray cable): For use with the [opto-coupled I/O lines](#) of Basler cameras connected to a programmable logic controller ([PLC](#)). It adapts the signal level for zero voltage from PLC level (<8.4 VDC) to TTL level (<1.4 VDC).

## Physical Interface

---

### Camera Connectors



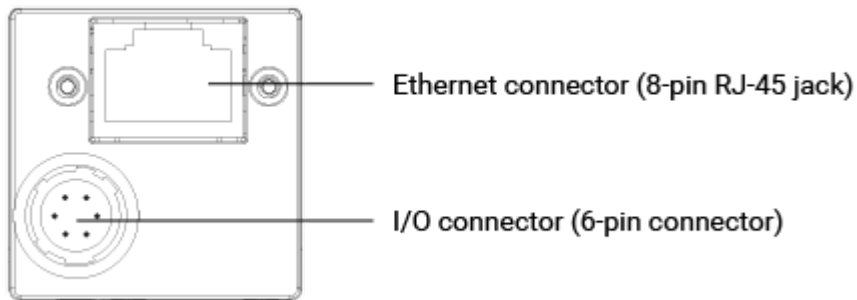

Connector	Description
Ethernet connector	<ul style="list-style-type: none"> <li>• 100/1000 Mbit/s Ethernet connection to the camera</li> <li>• If power is not supplied via I/O connector: Power over Ethernet (PoE)</li> <li>• 8-pin RJ-45 jack Recommended mating connector: 8-pin RJ-45 plug (snap-in or with locking screws).</li> <li>• When using locking screws, note the horizontal orientation of the screws.</li> </ul>
I/O Connector	<ul style="list-style-type: none"> <li>• If power is not supplied via Power over Ethernet (PoE): Power supply</li> <li>• Hirose micro receptacle (part number HR10A-7R-6PB) Recommended mating connector: Hirose micro plug (part number HR10A-7P-6S)</li> </ul>

## Connector Pin Numbering and Assignments

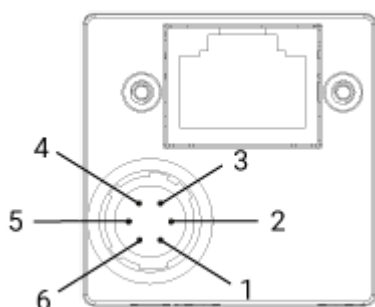

Pin	Line	Function
1	-	12 VDC camera power
2	Line 1	Opto-coupled I/O input line
3	-	Not connected
4	Out 1	Opto-coupled I/O output line

5	-	Ground for opto-coupled I/O lines
6	-	Ground for camera power

## Precautions

---

→ See [Safety Instructions for Basler ace Cameras](#).

## Installation

---

→ See [Camera Installation](#).

## Features

---

→ See the [camera features section](#).

---

Suggestions for improving the documentation? Send us your [feedback on this topic](#).

For technical questions, please contact your [local distributor](#) or use the [support form](#) on the Basler website.