

Panasonic
ideas for life

**HIGH CONTACT CAPACITY,
PRECISE OPERATION**

**AM1
(NZ BASIC)
SWITCHES**

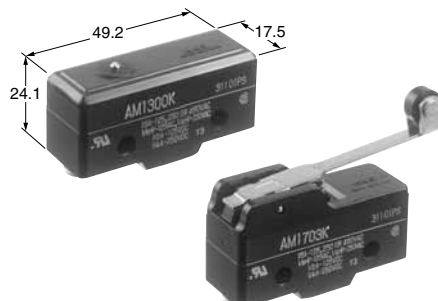

FEATURES

- 15 A High current switching capacity and high precision
- Wide allowance of operating speed
- Versatile variety of actuators
- UL/CSA approved

TYPICAL APPLICATION

- General industrial machinery
- Medical equipment
- Measuring instruments
- Transportation equipment
- Home electric appliances

ORDERING INFORMATION

Ex. AM 1 5 0 1 K

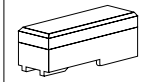
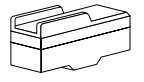
| Type of switch | Upper body cover shape & terminal | Basic specifications | Actuators |
|-----------------------|--|---|---|
| NZ basic (AM1) switch | 1: Flat, solder terminal 3: Flat, screw terminal 5: Grooved, solder terminal 7: Grooved, screw terminal Upper body cover shape Flat  Grooved  | 0: Standard type 1: Oil tight type 3: Reversed action type 4: One way type | 0: Pin plunger 1: Hinge lever (leaf spring) 3: Hinge roller lever (roller, leaf, spring) 4: Hinge short roller lever 5: Overtravel plunger 6: Compact overtravel plunger 7: Panel mount plunger 811: Panel mount roller plunger 812: Panel mount cross roller plunger |

Remarks: Not every combination is available. Please refer to the following table, "PRODUCT TYPES".

TERMINAL VARIATION

Standard types, reversed action types and oil tight types are available in two terminal designs, solder and screw terminals, as shown in the above columns:

Differences in dimension between solder and screw terminals are as follows;

mm

Solder terminal

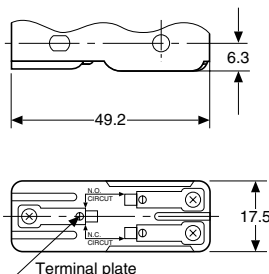

Screw terminal

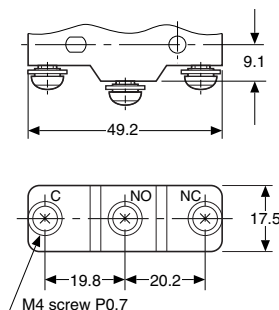

AM1

PRODUCT TYPES

1. Standard type

| Actuator | Solder terminal | Screw terminal |
|--|-----------------|----------------|
| Pin plunger | AM1100K | AM1300K |
| Over travel plunger | AM1105K | AM1305K |
| Compact over travel plunger | AM1106K | AM1306K |
| Panel mount plunger | AM1107K | AM1307K |
| Panel mount roller plunger | AM110811K | AM130811K |
| Panel mount cross roller plunger | AM110812K | AM130812K |
| Flexible leaf lever | AM1101K | AM1301K |
| Flexible roller leaf lever | AM1103K | AM1303K |
| Rigid lever | AM1501K | AM1701K |
| Rigid short roller lever | AM1504K | AM1704K |
| Rigid roller lever | AM1503K | AM1703K |
| One way type•Rigid short roller lever | AM1544K | AM1744K |
| One way type•Rigid roller lever | AM1543K | AM1743K |
| Reversed action type•Rigid lever | AM1531K | AM1731K |
| Reversed action type •Rigid short roller lever | AM1534K | AM1734K |
| Reversed action type•Rigid roller lever | AM1533K | AM1733K |

2. Oil tight types

| Actuator | Solder terminal | Screw terminal |
|--------------------------|-----------------|----------------|
| Rigid lever | AM1511K | AM1711K |
| Rigid short roller lever | AM1514K | AM1714K |
| Rigid roller lever | AM1513K | AM1713K |

Remarks: 1. Standard part number indicates UL/CSA mark.
2. Standard packing for inner carton: 20cps.

SPECIFICATIONS

1. Contact Rating

| Type | Voltage | Resistive load ($\cos \phi = 1$) | Inductive load ($\cos \phi = 0.6$ to 0.7) | Motor or lamp load | |
|--|----------|---------------------------------------|--|--------------------|--------|
| | | | | N.C. | N.O. |
| Standard types One way types Reversed action types | 125 V AC | 15 A | 10 A | 4 A | 2 A |
| | 250 V AC | 15 A | 10 A | 3 A | 1.5 A |
| | 480 V AC | 3 A | 2 A | 1.5 A | 0.75 A |
| | 125 V DC | 0.5 A | 0.05 A | — | — |
| | 250 V DC | 0.25 A | 0.03 A | — | — |
| Oil tight types | 125 V AC | 15 A | 10 A | 3 A | 1.5 A |
| | 250 V AC | 10 A | 6 A | 2 A | 1.0 A |
| | 125 V DC | 0.5 A | 0.05 A | — | — |

2. Characteristics

| Item | | Specifications |
|---|---|--|
| Expected life | Mechanical | Pin plunger types (O.T.: specified value) |
| | | Other types (O.T.: specified value) |
| | Electrical (O.T.: Max.) | |
| Insulation resistance | | Min. 100 M Ω (at 500 V DC) |
| Dielectric strength | Between open terminals | 1,000 Vrms for 1 min. |
| | Between each terminal and other exposed metal parts | 2,000 Vrms for 1 min. |
| | Between each terminal and ground | 2,000 Vrms for 1 min. |
| Contact resistance (initial) (by voltage drop, 1 A, 6–8 V DC) | | Max. 50 m Ω |
| Vibration resistance (Pin plunger type) | | Single amplitude: 0.75 mm, 10 to 55 Hz (contact opening: max. 1 msec.) |
| Shock resistance | Pin plunger types | Min. 300 m/s ² (contact opening: max. 1 msec.) |
| | Other types | Min. 50 m/s ² (contact opening: max. 1 msec.) |
| Allowable operating speed (at no load) | | 0.1 to 1,000 mm/sec. (at pin plunger position) |
| Max. operating cycle rate (at no load) | | 240 cpm |
| Ambient temperature | | –25°C to +80°C (no freezing at low temperature) |
| Weight | | Approx. 20 to 55 g |

OPERATING CHARACTERISTICS

Standard types

| Types of actuator | Pin plunger | Overtravel plunger | Compact overtravel plunger | Panel mount plunger |
|--------------------------------|-------------|--------------------|----------------------------|---------------------|
| Operating force, max. | 3.63 N | | | |
| Release force, min. | 1.12 N | | | |
| Pretravel, max. mm | 0.4 | | | |
| Movement differential, max. mm | 0.05 | | | |
| Overtravel, min. mm | 0.13 | 1.5 | 1.5 | 5.6 |
| Operating position, mm | 15.9±0.4 | 28.2±0.5 | 21.2±0.5 | 21.8±0.8 |

| Types of actuator | Panel mount roller plunger | Panel mount cross roller plunger | Flexible leaf lever | Flexible roller leaf lever |
|--------------------------------|----------------------------|----------------------------------|---------------------|----------------------------|
| Operating force, max. | 3.63 N | | 1.47 N | |
| Release force, min. | 1.12 N | | 0.14 N | |
| Pretravel, max. mm | 0.4 | | 4 | |
| Movement differential, max. mm | 0.05 | | 1.3 | |
| Overtravel, min. mm | 3.6 | | 1.6 | |
| Operating position, mm | 33.3±1.2 | | 17.5±0.8 | 28.6±0.8 |

Standard types (cont' d)

| Types of actuator | Rigid lever | Rigid short roller lever | Rigid roller lever |
|--------------------------------|-------------|--------------------------|--------------------|
| Operating force, max. | 0.69 N | 1.57 N | 0.98 N |
| Release force, min. | 0.14 N | 0.42 N | 0.2 N |
| Pretravel, max. mm | 10 | 4.5 | 7.5 |
| Movement differential, max. mm | 1.3 | 0.7 | 1.3 |
| Overtravel, min. mm | 5.6 | 2.4 | 3.6 |
| Operating position, mm | 19.1±0.7 | 30.2±0.4 | 30.2±0.7 |

One way types

| Types of actuator | Rigid short roller lever | Rigid roller lever |
|--------------------------------|--------------------------|--------------------|
| Operating force, max. | 2.23 N | 1.67 N |
| Release force, min. | 0.42 N | 0.42 N |
| Pretravel, max. mm | 3.5 | 4.5 |
| Movement differential, max. mm | 0.4 | 0.5 |
| Overtravel, min. mm | 1.5 | 2.4 |
| Free position, max. mm | 31.8 | 43.3 |
| Operating position, mm | 30.2±0.4 | 41.3±0.4 |

Reversed action types

| Types of actuator | Rigid lever | Rigid short roller lever | Rigid roller lever |
|--------------------------------|-------------|--------------------------|--------------------|
| Operating force, max. | 1.67 N | 5.30 N | 2.35 N |
| Release force, min. | 0.27 N | 1.67 N | 0.56 N |
| Pretravel, max. mm | 5.0 | 2.5 | 3.6 |
| Movement differential, max. mm | 0.9 | 0.4 | 0.7 |
| Overtravel, min. mm | 5.6 | 2.0 | 4.0 |
| Operating position, mm | 19.1±0.8 | 30.2±0.5 | 30.2±0.8 |

Oil tight types

| Types of actuator | Rigid lever | Rigid short roller lever | Rigid roller lever |
|--------------------------------|-------------|--------------------------|--------------------|
| Operating force, max. | 0.69 N | 1.67 N | 0.98 N |
| Release force, min. | 0.14 N | 0.42 N | 0.20 N |
| Pretravel, max. mm | 10 | 4.5 | 7.5 |
| Movement differential, max. mm | 1.5 | 0.7 | 1.3 |
| Overtravel, min. mm | 5.6 | 2.4 | 3.6 |
| Operating position, mm | 19.1±0.7 | 30.2±0.4 | 30.2±0.7 |

AM1

DIMENSIONS

mm General tolerance: ± 0.4

1. Standard types

Pin plunger



AM1100K (Solder terminal)
AM1300K (Screw terminal)

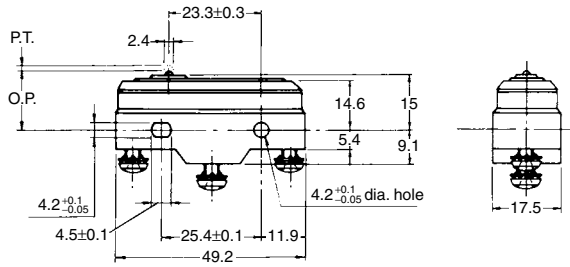

| | |
|--------------------------------|----------------|
| Operating force, max. | 3.63 N |
| Release force, min. | 1.12 N |
| Pretravel, max. mm | 0.4 |
| Movement differential, max. mm | 0.05 |
| Overtravel, min. mm | 0.13 |
| Operating position, mm | 15.9 \pm 0.4 |

Overtravel plunger



AM1105K (Solder terminal)
AM1305K (Screw terminal)

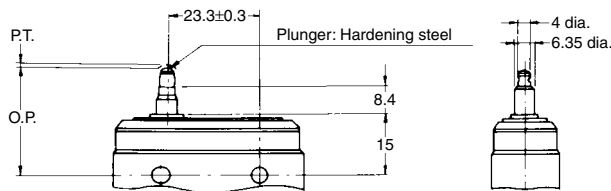

| | |
|--------------------------------|----------------|
| Operating force, max. | 3.63 N |
| Release force, min. | 1.12 N |
| Pretravel, max. mm | 0.4 |
| Movement differential, max. mm | 0.05 |
| Overtravel, min. mm | 1.5 |
| Operating position, mm | 28.2 \pm 0.5 |

Compact over plunger



AM1106K (Solder terminal)
AM1306K (Screw terminal)

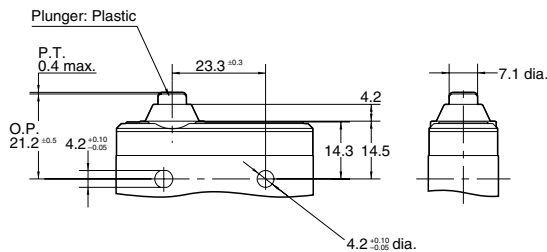

| | |
|--------------------------------|----------------|
| Operating force, max. | 3.63 N |
| Release force, min. | 1.12 N |
| Pretravel, max. mm | 0.4 |
| Movement differential, max. mm | 0.05 |
| Overtravel, min. mm | 1.5 |
| Operating position, mm | 21.2 \pm 0.5 |

Panel mount plunger



AM1107K (Solder terminal)
AM1307K (Screw terminal)

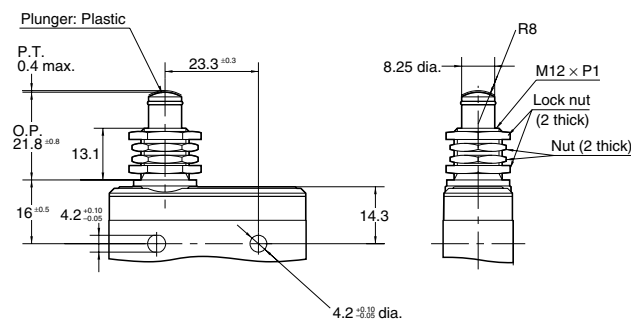

| | |
|--------------------------------|----------------|
| Operating force, max. | 3.63 N |
| Release force, min. | 1.12 N |
| Pretravel, max. mm | 0.4 |
| Movement differential, max. mm | 0.05 |
| Overtravel, min. mm | 5.6 |
| Operating position, mm | 21.8 \pm 0.8 |

Panel mount roller plunger

mm General tolerance: ± 0.4



AM110811K (Solder terminal)
AM130811K (Screw terminal)

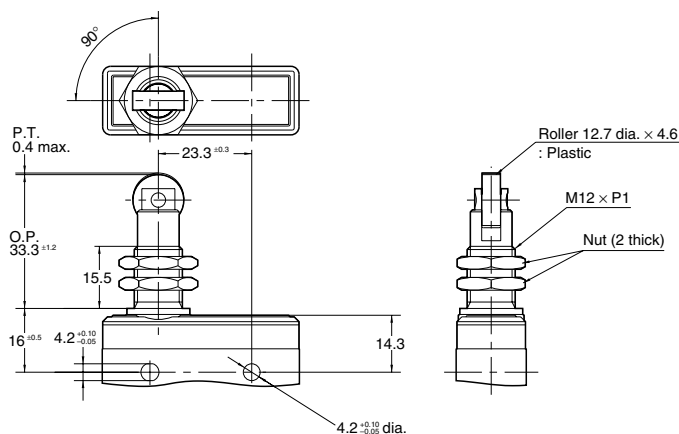

| | |
|--------------------------------|----------------|
| Operating force, max. | 3.63 N |
| Release force, min. | 1.12 N |
| Pretravel, max. mm | 0.4 |
| Movement differential, max. mm | 0.05 |
| Overtravel, min. mm | 3.6 |
| Operating position, mm | 33.3 ± 1.2 |

Panel mount cross roller plunger



AM110812K (Solder terminal)
AM130812K (Screw terminal)

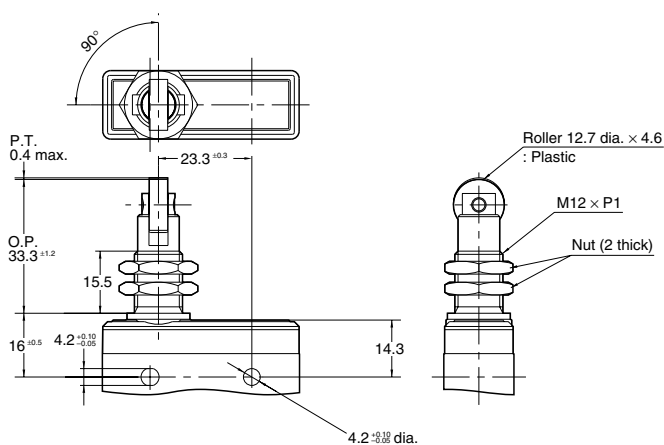

| | |
|--------------------------------|----------------|
| Operating force, max. | 3.63 N |
| Release force, min. | 1.12 N |
| Pretravel, max. mm | 0.4 |
| Movement differential, max. mm | 0.05 |
| Overtravel, min. mm | 3.6 |
| Operating position, mm | 33.3 ± 1.2 |

Dimensions and Operating characteristics are the same as those of Panel mount roller plunger type. However, the roller joins the switch body at an angle of 90°.

Flexible leaf lever



AM1101K (Solder terminal)
AM1301K (Screw terminal)

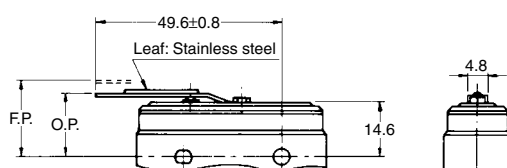

| | |
|--------------------------------|----------------|
| Operating force, max. | 1.47 N |
| Release force, min. | 0.14 N |
| Pretravel, max. mm | 4 |
| Movement differential, max. mm | 1.3 |
| Overtravel, min. mm | 1.6 |
| Operating position, mm | 17.5 ± 0.8 |

Flexible roller leaf lever



AM1103K (Solder terminal)
AM1303K (Screw terminal)

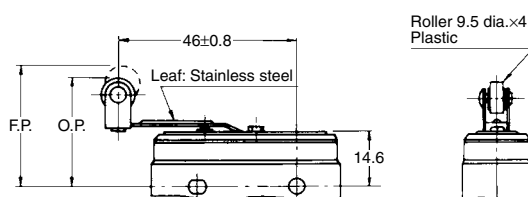

| | |
|--------------------------------|----------------|
| Operating force, max. | 1.47 N |
| Release force, min. | 0.14 N |
| Pretravel, max. mm | 4 |
| Movement differential, max. mm | 1.3 |
| Overtravel, min. mm | 1.6 |
| Operating position, mm | 28.6 ± 0.8 |

AM1

Rigid lever

mm General tolerance: ± 0.4

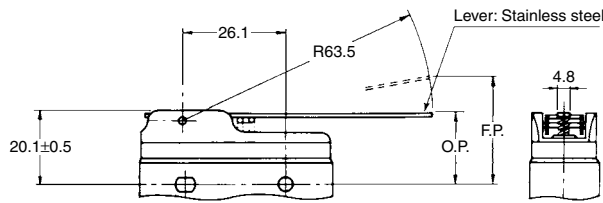

AM1501K (Solder terminal)
AM1701K (Screw terminal)

| | |
|--------------------------------|----------------|
| Operating force, max. | 0.69 N |
| Release force, min. | 0.14 N |
| Pretravel, max. mm | 10 |
| Movement differential, max. mm | 1.3 |
| Overtravel, min. mm | 5.6 |
| Operating position, mm | 19.1 \pm 0.7 |

Rigid short roller lever

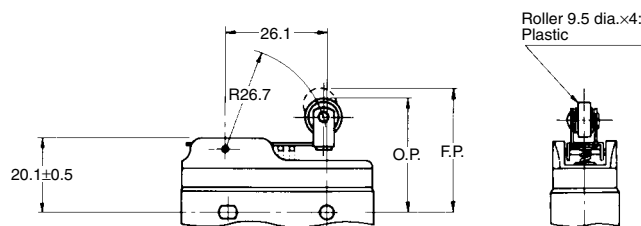

AM1504K (Solder terminal)
AM1704K (Screw terminal)

| | |
|--------------------------------|----------------|
| Operating force, max. | 1.57 N |
| Release force, min. | 0.42 N |
| Pretravel, max. mm | 4.5 |
| Movement differential, max. mm | 0.7 |
| Overtravel, min. mm | 2.4 |
| Operating position, mm | 30.2 \pm 0.4 |

Rigid roller lever

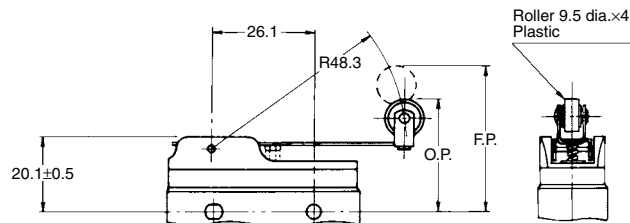

AM1503K (Solder terminal)
AM1703K (Screw terminal)

| | |
|--------------------------------|----------------|
| Operating force, max. | 0.98 N |
| Release force, min. | 0.2 N |
| Pretravel, max. mm | 7.5 |
| Movement differential, max. mm | 1.3 |
| Overtravel, min. mm | 3.6 |
| Operating position, mm | 30.2 \pm 0.7 |

2. One way types

This type is operated only to one direction, not to the reversed direction by the construction of the roller lever, pivoting away from the cam on the return stroke.

Rigid short roller lever

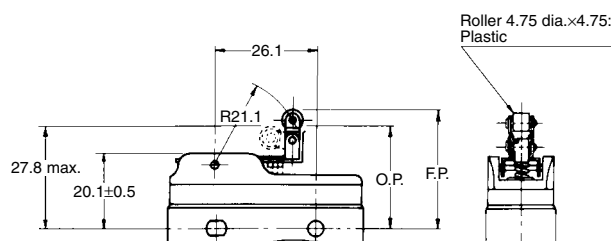

AM1544K (Solder terminal)
AM1744K (Screw terminal)

| | |
|--------------------------------|----------------|
| Operating force, max. | 2.23 N |
| Release force, min. | 0.42 N |
| Pretravel, max. mm | 3.5 |
| Movement differential, max. mm | 0.4 |
| Overtravel, min. mm | 1.5 |
| Operating position, mm | 30.2 \pm 0.4 |

Rigid roller lever

mm General tolerance: ± 0.4



AM1543K (Solder terminal)
AM1743K (Screw terminal)

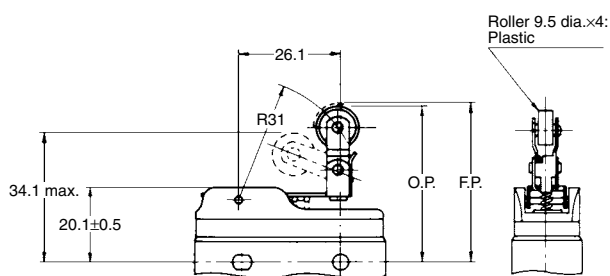

| | |
|--------------------------------|----------------|
| Operating force, max. | 1.67 N |
| Release force, min. | 0.42 N |
| Pretravel, max. mm | 4.5 |
| Movement differential, max. mm | 0.5 |
| Overtravel, min. mm | 2.4 |
| Operating position, mm | 41.3 \pm 0.4 |

3. Reversed action types

When the actuator is operated, the switching mechanism returns to the free position. Extraordinary force by pushing the plunger too much is not put on the switching mechanism, which means stability in life.

Rigid lever



AM1531K (Solder terminal)
AM1731K (Screw terminal)

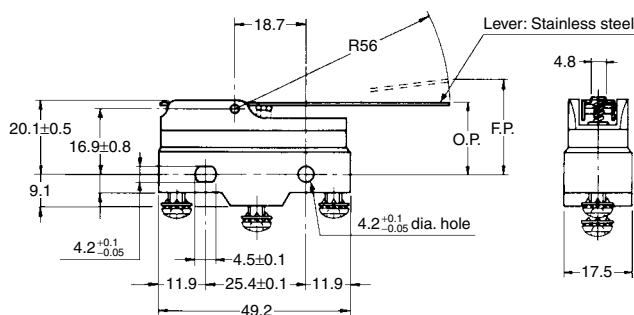

| | |
|--------------------------------|----------------|
| Operating force, max. | 1.67 N |
| Release force, min. | 0.27 N |
| Pretravel, max. mm | 5.0 |
| Movement differential, max. mm | 0.9 |
| Overtravel, min. mm | 5.6 |
| Operating position, mm | 19.1 \pm 0.8 |

Rigid short roller lever



AM1534K (Solder terminal)
AM1734K (Screw terminal)

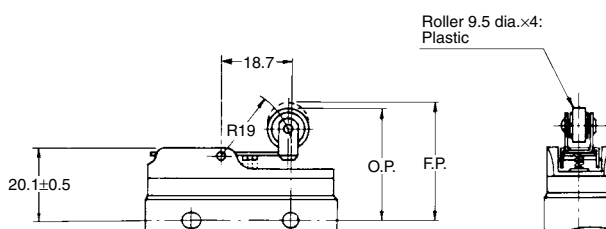

| | |
|--------------------------------|----------------|
| Operating force, max. | 5.30 N |
| Release force, min. | 1.67 N |
| Pretravel, max. mm | 2.5 |
| Movement differential, max. mm | 0.4 |
| Overtravel, min. mm | 2.0 |
| Operating position, mm | 30.2 \pm 0.5 |

Rigid roller lever



AM1533K (Solder terminal)
AM1733K (Screw terminal)

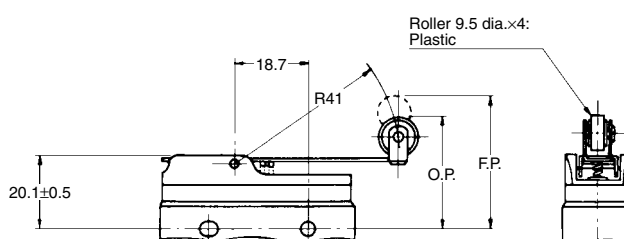

| | |
|--------------------------------|----------------|
| Operating force, max. | 2.35 N |
| Release force, min. | 0.56 N |
| Pretravel, max. mm | 3.6 |
| Movement differential, max. mm | 0.7 |
| Overtravel, min. mm | 4.0 |
| Operating position, mm | 30.2 \pm 0.8 |

AM1

4. Oil tight types

mm General tolerance: ± 0.4

The pushbutton part is sealed with the rubber cap and the connected part between the cap and body is also coated with resin so that these parts are kept away from foreign matters. This type has resistance to oil.

Rigid lever



AM1511K (Solder terminal)
AM1711K (Screw terminal)

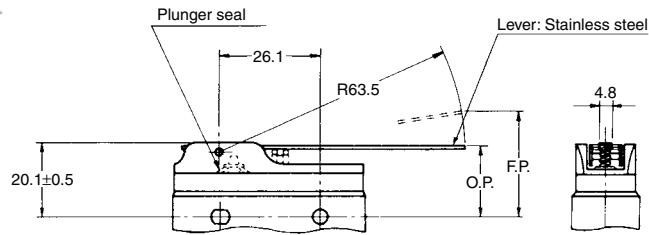

| | |
|--------------------------------|----------|
| Operating force, max. | 0.69 N |
| Release force, min. | 0.14 N |
| Pretravel, max. mm | 10 |
| Movement differential, max. mm | 1.5 |
| Overtravel, min. mm | 5.6 |
| Operating position, mm | 19.1±0.7 |

Rigid short roller lever



AM1514K (Solder terminal)
AM1714K (Screw terminal)

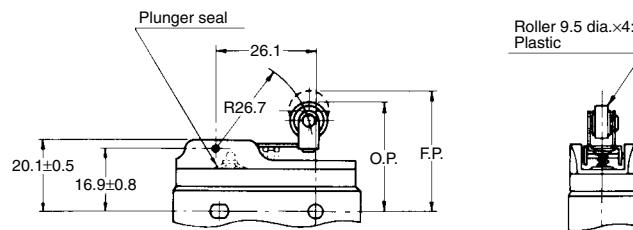

| | |
|--------------------------------|----------|
| Operating force, max. | 1.67 N |
| Release force, min. | 0.42 N |
| Pretravel, max. mm | 4.5 |
| Movement differential, max. mm | 0.7 |
| Overtravel, min. mm | 2.4 |
| Operating position, mm | 30.2±0.4 |

Rigid roller lever



AM1513K (Solder terminal)
AM1713K (Screw terminal)

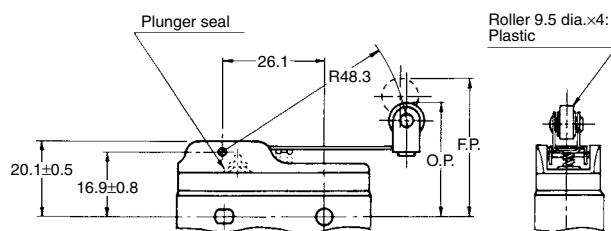

| | |
|--------------------------------|----------|
| Operating force, max. | 0.98 N |
| Release force, min. | 0.20 N |
| Pretravel, max. mm | 7.5 |
| Movement differential, max. mm | 1.3 |
| Overtravel, min. mm | 3.6 |
| Operating position, mm | 30.2±0.7 |

NOTES

1. Regarding fastening of switch body

1) In fastening the switch body, use M4 mounting screws to attach switches with the torque 1.5 N·m or less.

2) After mounting and wiring, the insulation distance between ground and each terminal should be confirmed as sufficient.

2. Adjustment of the operating device

The operating device should be positioned so that it applies no stress to the pushbutton or actuator when the switch is in the open position. If this condition is exceeded, the mechanical and electrical performance will be impaired. In addition, the force applied by the operating device should be in a perpendicular direction. Even if the pushbutton is used in the full total travel position, there will be no influence on the life of the switch.

3. Soldering operations

Soldering should be done in less than 5 seconds, with a 60 watt iron (tip temperature = 350°C max.). Care should be taken not to apply force to the terminal during soldering.

4. Avoid using switches in the following conditions:

- In corrosive gases such as hydrogen sulfide.
- In flammable or explosive gases such as gasoline or thinner etc.
- In a dusty environment.
- In an ambient humidity over 85%.
- In conditions where the perpendicular operating speed is less than 0.1 mm/sec. or more than 1,000 mm/sec.
- In a silicon atmosphere.

5. Others

Caution should be taken not to drop switches.