

BTL7-A/E501-M_____ -A/B/Y/Z(8)-S32/S115/S140
BTL7-A/E501-M_____ -A/B/Y/Z(8)-KA_/FA_

User's Guide

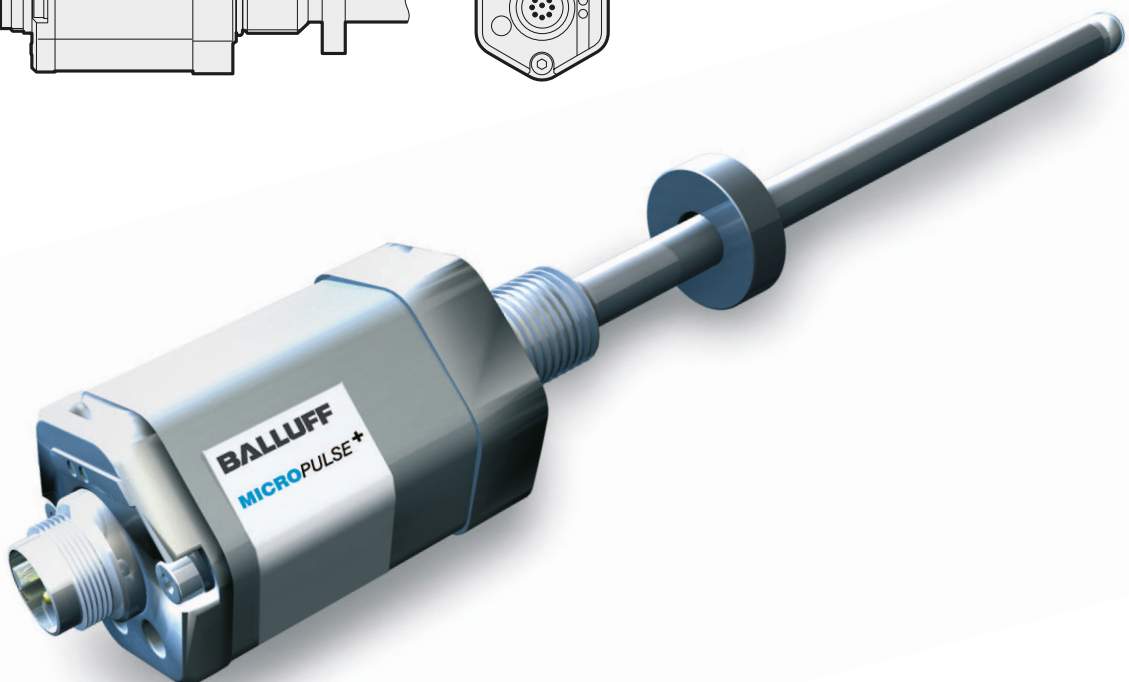
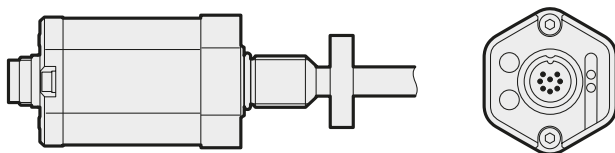

www.balluff.com

1	Notes to the user	5
1.1	Validity	5
1.2	Symbols and conventions	5
1.3	Scope of delivery	5
1.4	Approvals and markings	5
2	Safety	6
2.1	Intended use	6
2.2	General safety notes for the position measuring system	6
2.3	Meaning of the warnings	6
2.4	Disposal	6
3	Construction and function	7
3.1	Construction	7
3.2	Function	8
3.3	LED display	8
4	Installation and connection	9
4.1	Installation variants	9
4.2	Preparing for installation	9
4.3	Installing the transducer	10
4.3.1	Installation recommendation for hydraulic cylinders	10
4.4	Electrical connection	11
4.4.1	Connector S32/cable connection	11
4.4.2	Connector S115	11
4.4.3	Connector S140	12
4.5	Shielding and cable routing	12
5	Startup	13
5.1	Starting up the system	13
5.2	Operating notes	13
6	Configuration with the Micropulse Configuration Tool	14
6.1	Micropulse Configuration Tool	14
6.2	Connecting the USB communication box	14
6.3	Configuration options	14
7	Adjust with the calibration device (not with BTL7-...-S140)	16
7.1	Calibration device	16
7.2	Calibration procedure notes	16
7.3	Calibration procedure overview	17
7.3.1	Teach-in	17
7.3.2	Adjust	18
7.3.3	Reset	18
8	Teach-in with the calibration device	19
9	Adjust with the calibration device	20
10	Reset all values with the calibration device (reset)	23

11	Technical data	24
11.1	Accuracy	24
11.2	Ambient conditions	24
11.3	Supply voltage (external)	24
11.4	Output	24
11.5	Communication lines La, Lb	24
11.6	Dimensions, weights	25
12	Accessories	26
12.1	Magnets	26
12.2	Mounting nut	26
12.3	Connectors and cables	27
12.3.1	BKS-S32/S33M-00, freely configurable	27
12.3.2	BKS-S232/S233-PU-__, preassembled	27
12.3.3	BKS-S115/S116-PU-__, preassembled	28
12.3.4	BKS-S140-23-00, freely configurable	28
12.3.5	Plug-in system, 8-pin	28
12.4	USB communication box	29
13	Type code breakdown	30
14	Appendix	31
14.1	Converting units of length	31
14.2	Part labels	31

BTL7-A/E501-M___-A/B/Y/Z(8)-S32/S115/S140/KA__/FA__ Micropulse Transducer - Rod Style

1

Notes to the user

1.1 Validity

This guide describes the construction, function and setting options for the BTL7 Micropulse Transducer with analog interface. It applies to types **BTL7-A/E501-M___-A/B/Y/Z(8)-S32/S115/S140/KA__/FA__** (see type code breakdown on page 30).

The guide is intended for qualified technical personnel. Read this guide before installing and operating the transducer.

1.2 Symbols and conventions

Individual **instructions** are indicated by a preceding triangle.

► Instruction 1

Action sequences are numbered consecutively:

1. Instruction 1
2. Instruction 2



Note, tip

This symbol indicates general notes.



These symbols indicate the buttons on the calibration device.



Symbols of this type indicate the LED displays.

1.3 Scope of delivery

- BTL7 transducer
- Calibration device (not with BTL7-...-S140)
- Condensed guide



The magnets are available in various models and must be ordered separately.

1.4 Approvals and markings



UL approval¹⁾
File no.
E227256

¹⁾ Not for BTL7-...-FA__

US Patent 5 923 164

The US patent was awarded in connection with this product.



The CE Mark verifies that our products meet the requirements of EU Directive 2004/108/EC (EMC Directive).

The transducer meets the requirements of the following generic standards:

- EN 61000-6-1 (noise immunity)
- EN 61000-6-2 (noise immunity)
- EN 61000-6-3 (emission)
- EN 61000-6-4 (emission)

and the following product standard:

- EN 61326-2-3

Emission tests:

- RF emission
EN 55016-2-3 (industrial and residential areas)

Noise immunity tests:

- Static electricity (ESD)
EN 61000-4-2 Severity level 3
- Electromagnetic fields (RFI)
EN 61000-4-3 Severity level 3
- Electrical fast transients (burst)
EN 61000-4-4 Severity level 3
- Surge
EN 61000-4-5 Severity level 2
- Conducted interference induced by high-frequency fields
EN 61000-4-6 Severity level 3
- Magnetic fields
EN 61000-4-8 Severity level 4



More detailed information on the guidelines, approvals, and standards is included in the declaration of conformity.



By using the GL symbol¹⁾, we confirm that the marked products were type tested according to the guidelines of Germanischer Lloyd.

The type approval is authenticated with a certificate.

The verified test requirements cover the environmental category "D" (closed environments with increased heat and vibration requirements).

Therefore, the marked products can be used according to the specifications of the certificate on ocean-going and inland vessels and on offshore operations in systems subject to mandatory type-testing.

Maximum length:

- BTL7-...-A/B/Y/Z-...: 300 mm (500 mm when supported at the end of the rod using slide bush BAM PC-TL-001-D10,4-4 in bore with a diameter of max. 13 mm)

¹⁾ Not for BTL7-...-S140

2

Safety

2.1 Intended use

The BTL7 Micropulse Transducer, together with a machine controller (e. g. PLC), comprises a position measuring system. It is intended to be installed into a machine or system. Flawless function in accordance with the specifications in the technical data is ensured only when using original BALLUFF accessories, use of any other components will void the warranty.

Opening the transducer or non-approved use are not permitted and will result in the loss of warranty and liability claims against the manufacturer.

2.2 General safety notes for the position measuring system

Installation and **startup** may only be performed by trained specialists with basic electrical knowledge.

Qualified personnel are those who can recognize possible hazards and institute the appropriate safety measures due to their professional training, knowledge, and experience, as well as their understanding of the relevant regulations pertaining to the work to be done.

The **operator** is responsible for ensuring that local safety regulations are observed.

In particular, the operator must take steps to ensure that a defect in the position measuring system will not result in hazards to persons or equipment.

If defects and unresolvable faults occur in the transducer, it should be taken out of service and secured against unauthorized use.

2.3 Meaning of the warnings

Always observe the warnings in these instructions and the measures described to avoid hazards.

The warnings used here contain various signal words and are structured as follows:

SIGNAL WORD
Hazard type and source Consequences if not complied with ► Measures to avoid hazards

The individual signal words mean:

NOTICE! Identifies a hazard that could damage or destroy the product .
 DANGER The general warning symbol in conjunction with the signal word DANGER identifies a hazard which, if not avoided, will certainly result in death or serious injury .

2.4 Disposal

- Observe the national regulations for disposal.

BTL7-A/E501-M___-A/B/Y/Z(8)-S32/S115/S140/KA___/FA___ Micropulse Transducer - Rod Style

3

Construction and function

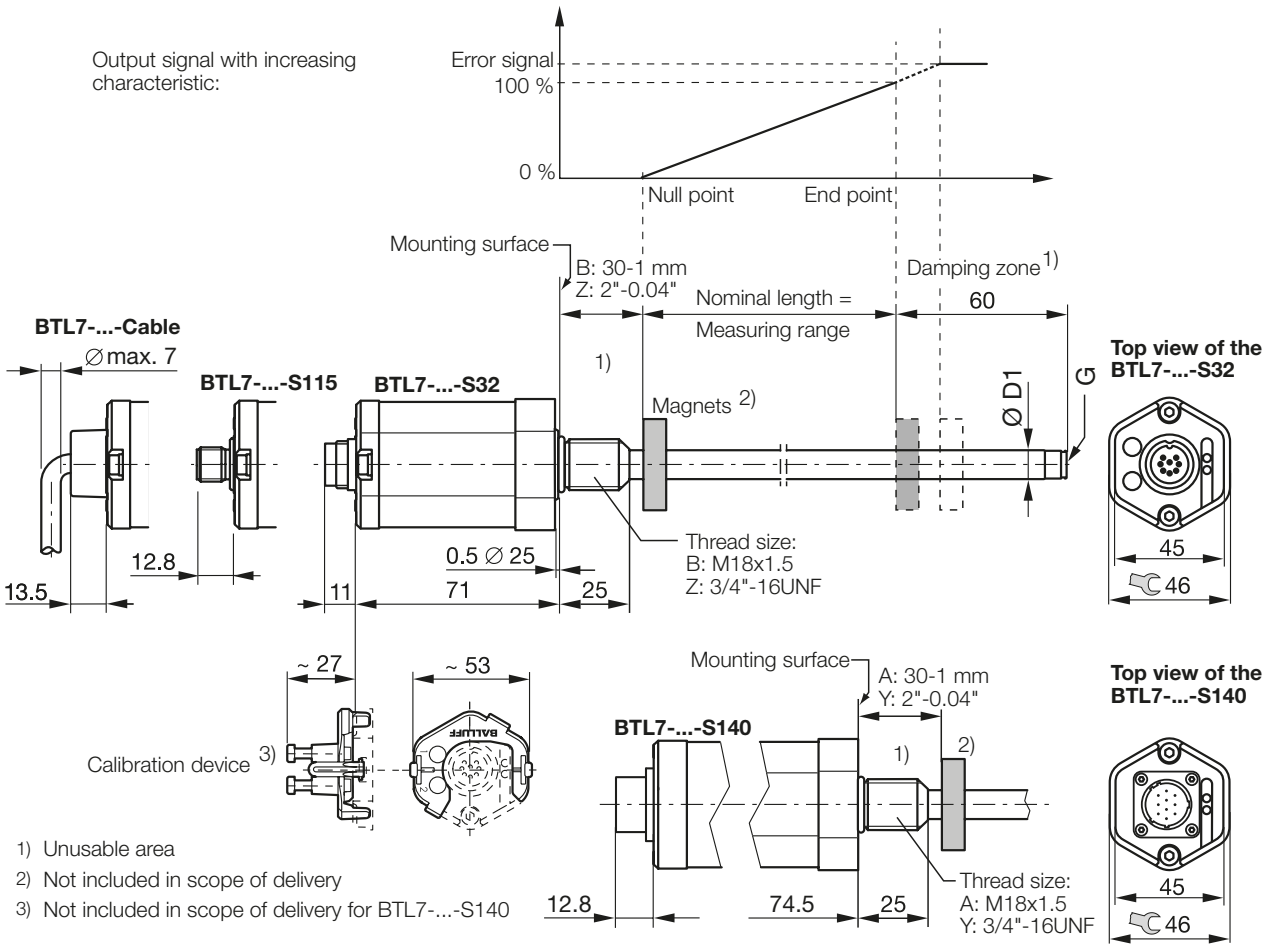

Version	D1	G
...-A/B/Y/Z-...	10.2 mm	Thread M4x4/6 deep
...-A8/B8/Y8/Z8-...	8 mm	No thread

Fig. 3-1: BTL7... transducer, construction and function

3.1 Construction

Electrical connection: The electrical connection is made via a cable or a connector (see type code breakdown on page 30).

BTL housing: Aluminum housing containing the processing electronics.

Mounting thread: We recommend assembling this transducer on the fastening screw thread:

- BTL7-...-A/B: M18x1.5
- BTL7-...-Y/Z: 3/4"-16UNF

The transducers with Ø 10.2 mm have an additional thread at the end of the rod to support larger nominal lengths.

Magnet: Defines the position to be measured on the waveguide. Magnets are available in various models and must be ordered separately (see accessories on page 26).

Nominal length: Defines the available measuring range. Rods with various nominal lengths from 25 mm to 7620 mm are available depending on the version:

- Ø 10.2 mm: Nominal length from 25 mm to 7620 mm
- Ø 8 mm: Nominal length from 25 mm to 1016 mm

Damping zone: Area at the end of the rod that cannot be used for measurements, but which may be passed over.

Calibration device: Additional device for calibrating the transducer (not with BTL7-...-S140).

3

Construction and function (continued)

3.2 Function

The Micropulse Transducer contains the waveguide which is protected by an outer stainless steel tube (rod). A magnet is moved along the waveguide. This magnet is connected to the system part whose position is to be determined.

The magnet defines the position to be measured on the waveguide.

An internally generated INIT pulse interacts with the magnetic field of the magnet to generate a torsional wave in the waveguide which propagates at ultrasonic speed.

The component of the torsional wave which arrives at the end of the waveguide is absorbed in the damping zone to prevent reflection. The component of the torsional wave which arrives at the beginning of the waveguide is converted by a coil into an electrical signal. The travel time of the wave is used to calculate the position. Depending on the version, this information is made available as a voltage or current with rising or falling gradient.

The following functions can be selected for the output values:

- Position
- Velocity (with or without leading sign)
- Differential position

Two outputs that can be independently assigned are available. Two magnets can be used.

i The entire function scope can only be configured with the PC software "Micropulse Configuration Tool". To do this, the USB communication box must be connected (see Accessories on page 26). If you do not have the PC software, the transducer can be adjusted using the calibration device (see page 17 ff).

3.3 LED display

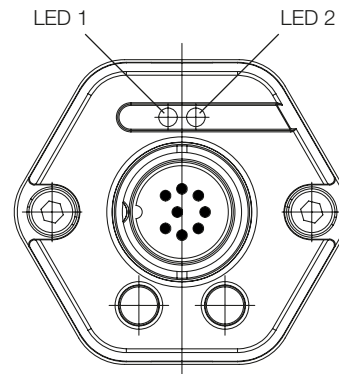

Fig. 3-2: Position of the BTL7 LED displays

i In normal operation, the LEDs indicate the operating states of the transducer. LED 1 is assigned to output 1, LED 2 is assigned to output 2 (see page 19 ff).

LED 1/LED 2	Operating state
Green	Normal function Magnet is within the limits.
Red	Error No magnet or magnet outside the limits.

Tab. 3-1: LED displays in normal operation

4

Installation and connection

4.1 Installation variants

Non-magnetizable material

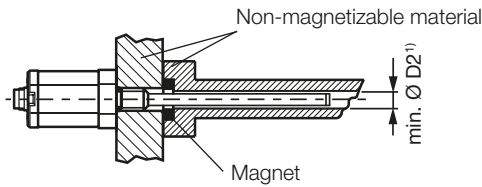

¹) Min. Ø D2 = Minimum diameter of the bore (see Tab. 4-1)

Fig. 4-1: Installation variant in non-magnetizable material

Magnetizable material

If using magnetizable material, the transducer must be protected against magnetic interference through suitable measures (e.g. spacer ring made of non-magnetizable material, a suitable distance from strong external magnetic fields).

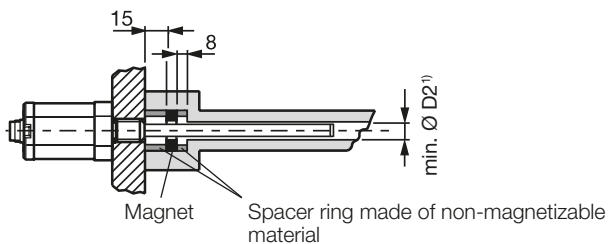
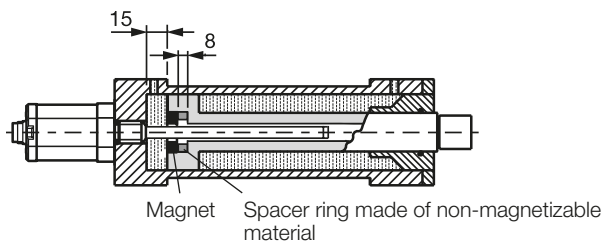

¹) Min. Ø D2 = Minimum diameter of the bore (see Tab. 4-1)

Fig. 4-2: Installation in magnetizable material

Tube diameter	Bore diameter D2
10.2 mm	At least 13 mm
8 mm	At least 11 mm

Tab. 4-1: Bore diameter if installed in a hydraulic cylinder

4.2 Preparing for installation

Installation note: We recommend using non-magnetizable material to mount the transducer and magnet.

Horizontal assembly: If installing horizontally with nominal lengths > 500 mm, we recommend tightening the rod at the end (only possible with Ø 10.2 mm) or supporting it.

Hydraulic cylinder: If installed in a hydraulic cylinder, ensure that the minimum value for the bore diameter of the support piston is complied with (see Tab. 4-1).

Mounting hole: The transducer comes with an M18x1.5 (ISO) or 3/4"-16UNF (SAE) mounting thread. Depending on the version, a mounting hole must be made before assembly.

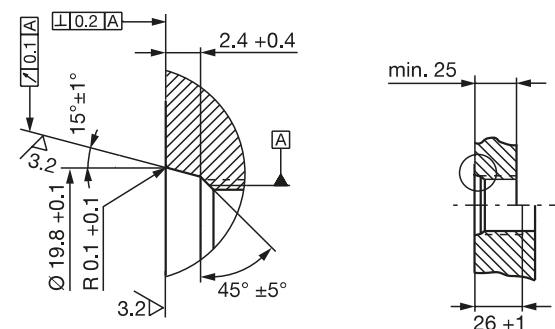

Fig. 4-3: Mounting hole M18x1.5 per ISO 6149 O-ring 15.4x2.1

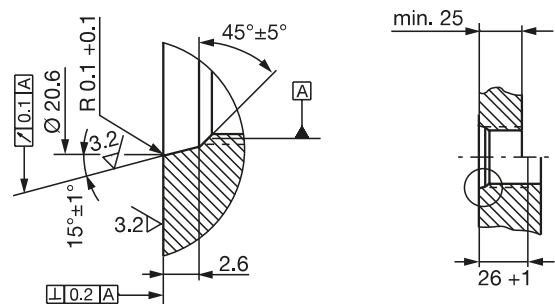

Fig. 4-4: Mounting hole 3/4"-16UNF per SAE J475 O-ring 15.3x2.4

Magnet: Various magnets are available for the BTL7 transducer (see Accessories on page 26).

4

Installation and connection (continued)

4.3 Installing the transducer

NOTICE!

Interference in function

Improper installation can compromise the function of the transducer and result in increased wear.

- ▶ The mounting surface of the transducer must make full contact with the supporting surface.
- ▶ The bore must be perfectly sealed (O-ring/flat seal).

- ▶ Make a mounting hole with thread (possibly with countersink for the O-ring) acc. to Fig. 4-3 or Fig. 4-4.
- ▶ Screw the transducer with fastening screw thread into the mounting hole (max. torque 100 Nm).
- ▶ Install the magnet (accessories).
- ▶ For nominal lengths > 500 mm: Tighten the rod at the end (only possible with Ø 10.2 mm) or support it.

i Suitable nuts for the mounting thread are available as accessories (see page 26).

4.3.1 Installation recommendation for hydraulic cylinders

If you seal the hole with a flat seal, the max. operating pressure will be reduced in accordance with the larger pressurized surface.

If installing horizontally in a hydraulic cylinder (nominal lengths > 500 mm), we recommend affixing a slide element to protect the rod end from wear.

i Dimensioning of the detailed solutions is the responsibility of the cylinder manufacturer.

The slide element material must be suitable for the appropriate load case, medium used, and application temperatures. E.g. Torlon, Teflon or bronze are all possible materials.

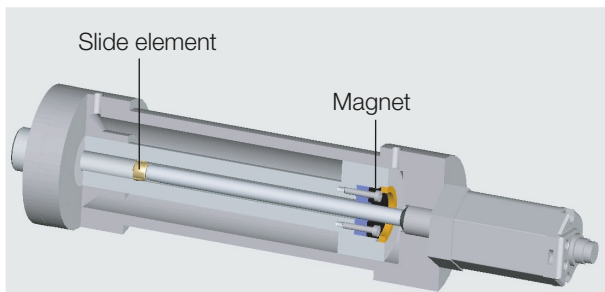

Fig. 4-5: Example 1, transducer installed with slide element

The slide element can be screwed on or bonded.

- ▶ Secure the screws so they cannot be loosened or lost.
- ▶ Select a suitable adhesive.

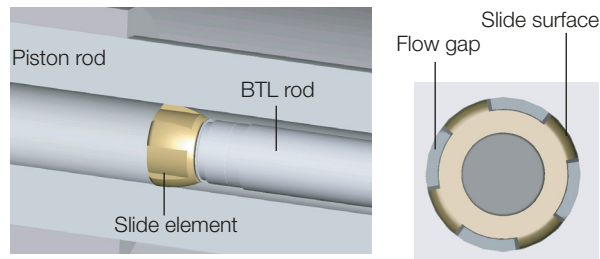

Fig. 4-6: Detailed view and top view of slide element

There must be a gap between the slide element and piston bore that is sufficiently large for the hydraulic oil to flow through.

Options for fixing the magnet:

- Screws
- Threaded ring
- Press fitting
- Notches (center punching)

i If installed in a hydraulic cylinder, the magnet should not make contact with the rod.

The hole in the spacer ring must ensure optimum guidance of the rod by the slide element.

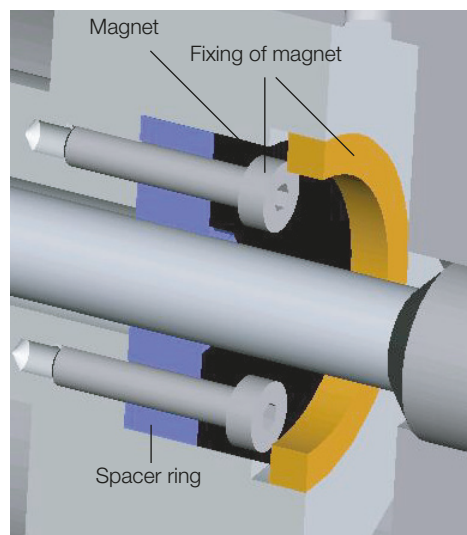

Fig. 4-7: Fixing of magnet

An example of how to install the transducer with a supporting rod is shown in Fig. 4-8 on page 11.

BTL7-A/E501-M___-A/B/Y/Z(8)-S32/S115/S140/KA___/FA___ Micropulse Transducer - Rod Style

4

Installation and connection (continued)

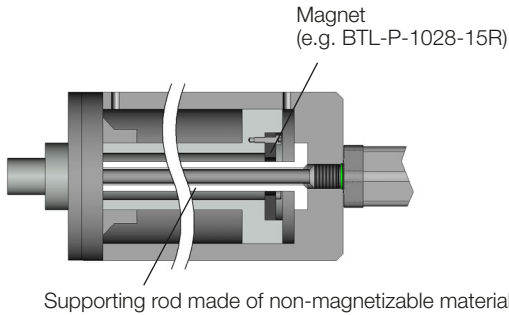

Fig. 4-8: Example 2, transducer installed with supporting rod

4.4 Electrical connection

Depending on the model, the electrical connection is made using a cable or a connector.
The connection or pin assignments for the respective version can be found in Tab. 4-2 to Tab. 4-4.

i Note the information on shielding and cable routing on page 12.

4.4.1 Connector S32/cable connection

S32 Pin	Cable color	BTL7-... interface	
		-A501	-E501
1	YE yellow	Not used ¹⁾	4 to 20 mA ²⁾ (output 1)
2	GY gray	0 V	
3	PK pink	10 to 0 V ²⁾ (output 2)	20 to 4 mA ²⁾ (output 2)
4	RD red	La (communication line)	
5	GN green	0 to 10 V ²⁾ (output 1)	Not used ¹⁾
6	BU blue	GND ³⁾	
7	BN brown	10 to 30 V	
8	WH white	Lb (communication line)	

Tab. 4-2: Connection assignment BTL7...S32/cable

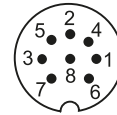

Fig. 4-9: Pin assignment of S32 connector (view of connector pins of transducer)

4.4.2 Connector S115

S115 Pin	BTL7-... interface	
	-A501	-E501
1	0 V (pin 3)	
2	0 V (pin 5)	
3	10 to 0 V ²⁾ (output 2)	20 to 4 mA ²⁾ (output 2)
4	La (communication line)	
5	0 to 10 V ²⁾ (output 1)	4 to 20 mA ²⁾ (output 1)
6	GND ³⁾	
7	10 to 30 V	
8	Lb (communication line)	

Tab. 4-3: Connection assignment BTL7...S115

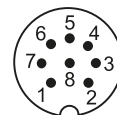

Fig. 4-10: Pin assignment of S115 connector (view of connector pins of transducer)

¹⁾ Unassigned leads can be connected to the GND on the controller side but not to the shield.

²⁾ Factory setting, can be freely configured with the PC software.

³⁾ Reference potential for supply voltage and EMC-GND.

4

Installation and connection (continued)

4.4.3 Connector S140

S140 Pin	BTL7-... interface	
	-A501	-E501
A	0 V	
B	Not used ¹⁾	4 to 20 mA ²⁾ (output 1)
C	10 to 0 V ²⁾ (output 2)	20 to 4 mA ²⁾ (output 2)
D	10 to 30 V	
E	Not used ¹⁾	
F	GND ³⁾	
G	La (communication line)	
H	Lb (communication line)	
J	0 to 10 V ²⁾ (output 1)	Not used ¹⁾
K	Not used ¹⁾	

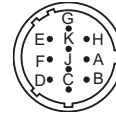

Fig. 4-11: Pin assignment of S140 (view of connector pins of transducer), 10-pin circular plug

Tab. 4-4: Connection assignment BTL7...-S140

¹⁾ Unassigned leads can be connected to the GND on the controller side but not to the shield.

²⁾ Factory setting, can be freely configured with the PC software.

³⁾ Reference potential for supply voltage and EMC-GND.

4.5 Shielding and cable routing



Defined ground!

The transducer and the control cabinet must be at the same ground potential.

Shielding

To ensure electromagnetic compatibility (EMC), observe the following:

- Connect transducer and controller using a shielded cable.
Shield: Braided copper shield with minimum 85% coverage.
- Connector version: Shield is internally connected to connector housing.
- Cable version: On the transducer side, the cable shielding is connected to the housing. Ground the cable shielding on the controller side (connect with the protective earth conductor).

Magnetic fields

The position measuring system is a magnetostrictive system. It is important to maintain adequate distance between the transducer cylinder and strong, external magnetic fields.

Cable routing

Do not route the cable between the transducer, controller, and power supply near high voltage cables (inductive stray noise is possible).

The cable must be routed tension-free.

Bending radius for fixed cable

The bending radius for a fixed cable must be at least five times the cable diameter.

Cable length

BTL7-A	Max. 30 m ¹⁾
BTL7-E	Max. 100 m ¹⁾

Tab. 4-5: Cable lengths BTL7

¹⁾ Prerequisite: Construction, shielding and routing preclude the effect of any external noise fields.

5

Startup

5.1 Starting up the system

DANGER

Uncontrolled system movement

When starting up, if the position measuring system is part of a closed loop system whose parameters have not yet been set, the system may perform uncontrolled movements. This could result in personal injury and equipment damage.

- ▶ Persons must keep away from the system's hazardous zones.
- ▶ Startup must be performed only by trained technical personnel.
- ▶ Observe the safety instructions of the equipment or system manufacturer.

1. Check connections for tightness and correct polarity. Replace damaged connections.
2. Turn on the system.
3. Check measured values and adjustable parameters and readjust the transducer, if necessary.



Check for the correct values at the null point and end point, especially after replacing the transducer or after repair by the manufacturer.

5.2 Operating notes

- Check the function of the transducer and all associated components on a regular basis.
- Take the position measuring system out of operation whenever there is a malfunction.
- Secure the system against unauthorized use.

6

Configuration with the Micropulse Configuration Tool

6.1 Micropulse Configuration Tool

NOTICE!
Interference in function
Configuration with the Micropulse Configuration Tool while the system is running may result in malfunctions.
▶ Stop the system before configuration.

The BTL7-A/E... USB-Configurable transducer can be configured quickly and simply on a PC using the Micropulse Configuration Tool PC software.

The most important features include:

- Online display of the current position of the magnet
- Graphical support for setting the functions and curves
- Display of information on the connected transducer
- Selectable number formats and units for display
- Resetting to factory settings is possible
- Demo mode without having transducer connected

i The PC software and associated manual can be found in the Internet under www.balluff.com/downloads-bt17.

6.2 Connecting the USB communication box

With BTL7-A/E... transducers with connectors, the communication box must be looped in between the transducer and controller. The communication box is connected to the PC via a USB cable.

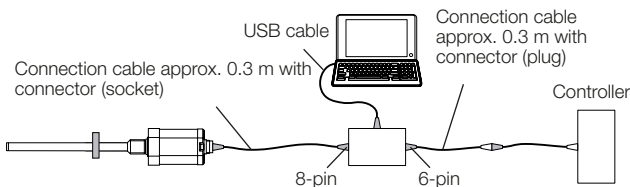

Fig. 6-1: Connecting the communication box with a connector

With a BTL7-A/E...-Cable transducer, the communication lines La, Lb and GND must be connected to the USB communication box.

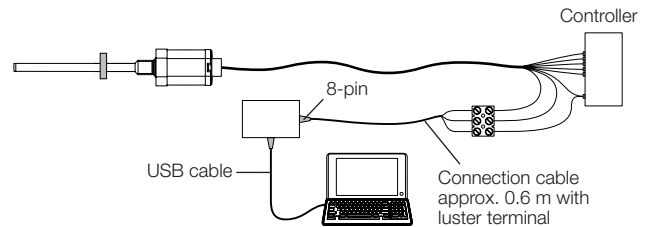

Fig. 6-2: Connecting the communication box with a cable connection

i When reading or writing data via the Configuration Tool, both LEDs flash green.

6.3 Configuration options

Prerequisites

- USB communication box connected to the transducer and PC.
- Software correctly installed.
- Transducer connected to the power supply.
- Magnet on transducer.

Magnets and outputs

- One or two magnets can be selected (factory setting: one magnet)
- Two outputs can be assigned independently

Output functions

- **Position:** position in the measuring range.
- **Velocity:** velocity of the magnet. The sign indicates the direction of movement. Movement from the null point to the end point is output with a positive sign. Movement from the end point to the null point is output with a negative sign. Max. detectable velocity range of -10 to +10 m/s.
- **Velocity (no sign):** velocity of the magnet. The direction of movement cannot be read. Max. detectable velocity range of 0 to 10 m/s.
- **Differential position:** Distance between two magnets. Selection is only possible if two magnets have been selected.

6

Configuration with the Micropulse Configuration Tool (continued)

Freely configurable curve

- Null and end points can be read (teach-in) or specified with the mouse.
- For position, the distance between the null point and end point must be at least 4 mm (0.15 inch) and 100 mm/s (4 inch/s) for velocity.
- The curve can be inverted or copied from the other output.
- The limits can be adjusted to the measuring range.
- The error value can be set in accordance with the limits.

Boundary conditions for two magnets

- Two magnets can only be selected if the nominal length is ≥ 90 mm.
- The distance between two magnets must be ≥ 65 mm.

Locking the calibration device

The function to manually adjust the transducer with the calibration device can be locked, making configuration only possible with the PC software.

! DANGER

Uncontrolled system movement

When starting up, if the position measuring system is part of a closed loop system whose parameters have not yet been set, the system may perform uncontrolled movements. This could result in personal injury and equipment damage.

- ▶ The system must be taken out of operation before configuration.
- ▶ Transducers may only be connected to the communication box for configuration.
- ▶ The communication box must be removed after configuration.

7

Adjust with the calibration device (not with BTL7-...-S140)

7.1 Calibration device

The calibration device is an additional device for calibrating the transducer if configuration with a PC and software is not possible.

Prerequisite

- Button function has not been locked by the PC software (button lock).
- Calibration device is in place
- The transducer is connected to the system controller.
- Voltage or current values from the transducer can be read (using a multimeter or the system controller).

i If the button function is locked, this lock must be removed using the PC software.

Settings

The transducer has the following factory settings that can be adjusted with the calibration device:

- One magnet,
- "position" function at both outputs, output 1 with a rising curve and output 2 with a falling curve,
- identical measuring range for both outputs.

During adjustment, the same start points and end points are set for both outputs. No other function can be selected and no further transducer may be used.

If the button function is locked, the lock can only be removed if these conditions have been fulfilled.

7.2 Calibration procedure notes

- ▶ Before calibrating: Place the calibration device on the connection side of the transducer.
- ▶ When finished with calibration: Remove the calibration device to prevent changes.
- ▶ Keep the calibration device for later use.

i Automatic deactivation!
 If the buttons on the calibration device are not pressed for approx. 10 min, programming mode is automatically ended.

Values for null and end point

- Any desired position of the magnet can be used as the null or end point. However, the null and end points may not be reversed.
- The absolute null and end points must lie within the minimum or maximum limits of what can be output.
- The distance between the null point and end point must be at least 4 mm.

i The last set values are always saved, regardless of whether the setting was ended using the buttons or automatically after 10 min have expired.

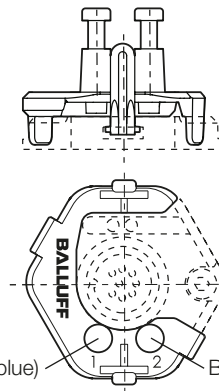
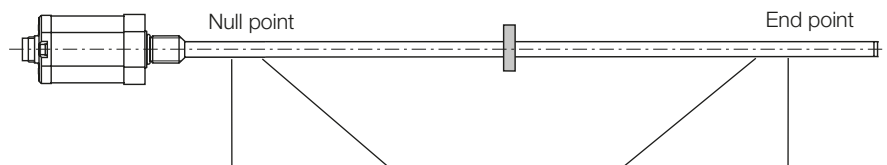

Fig. 7-1: Calibration device in place



Output gradient	Linear transducer	Unit	Min. value	Null value	End value	Max. value	Error value
Rising (output 1)	BTL7-A...	V	-0.5	0	+10.0	+10.5	+10.5
	BTL7-E...	mA	3.6	4.0	20.0	20.4	3.6
Falling (output 2)	BTL7-A...	V	+10.5	+10.0	0	-0.5	-0.5
	BTL7-E...	mA	20.4	20.0	4.0	3.6	3.6

Tab. 7-1: Factory settings value table

7

Adjust with the calibration device (continued)

7.3 Calibration procedure overview

7.3.1 Teach-in

i The detailed procedure for teach-in is described on page 20.

The factory set null point and end point is replaced by a new null point and end point. The null point and end point can be set separately, the output gradient changes.

Steps

- ▶ Move magnet to the new null position.
- ▶ Read new null point by pressing the buttons.
 ⇒ The current end point remains the same.

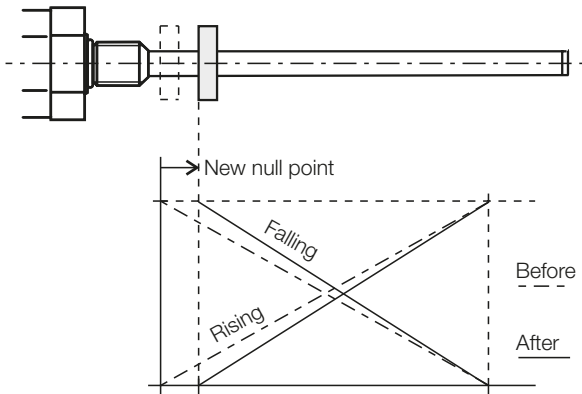

Fig. 7-2: Reading new null point

- ▶ Move magnet to the new end position.
- ▶ Read new end point by pressing the buttons.
 ⇒ The current null point remains the same.

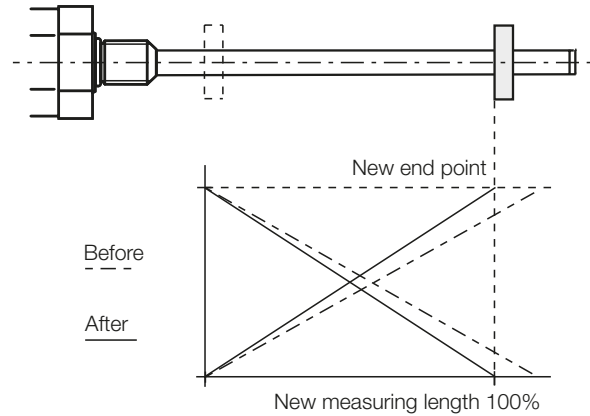

Fig. 7-3: Reading new end point

- ▶ The curves can be inverted by actuating the button.
 ⇒ During inverting, the curves of both outputs are inverted. For example, a rising curve for output 1 is changed to a falling curve and a falling curve from output 2 is changed to a rising curve.

7

Adjust with the calibration device (continued)

7.3.2 Adjust

i The detailed procedure for adjustment is described on page 21 ff.

The factory set null point and end point is replaced by a new start point and end point and the associated output values can be adjusted. The start and end values can be adjusted as you like up to the limits. The change to the output value can be read out at output 1 (in the delivery state).

i As standard, the values are adjusted at output 1 and the values at output 2 are inverted accordingly. From serial number 100503000xxxxx xx, it is possible to optionally switch adjustment from output 1 to output 2 (see page 22).

Steps

- ▶ Move magnet to the new start position.
- ▶ Read new start point by pressing the buttons.
- ▶ Set the new start value by pressing the buttons.

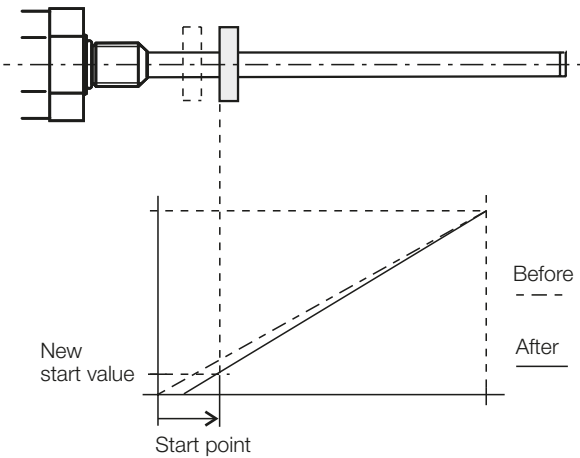

Fig. 7-4: Adjust a new start value

- ▶ Move magnet to the new end position.
- ▶ Read new end point by pressing the buttons.
- ▶ Set the new end value by pressing the buttons.

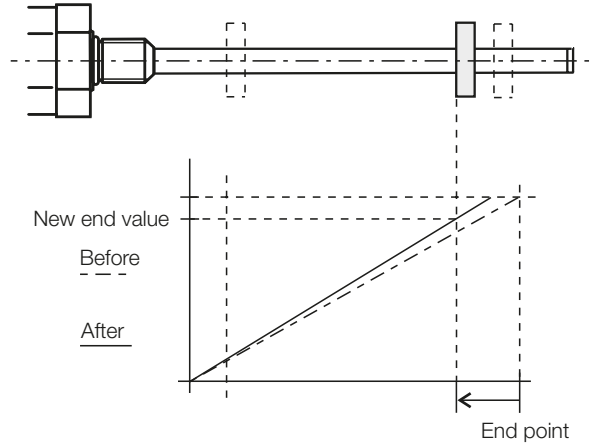

Fig. 7-5: Adjust a new end value

7.3.3 Reset

i The detailed procedure for the reset is described on page 23.

Restoring the transducer to its factory settings.

8

Teach-in with the calibration device

NOTICE!

Interference in function

Teach-in while the system is running may result in malfunctions.

- ▶ Stop the system before performing teach-in.

LED display Displayed values (example)

LED1 LED2 At 0 to 10 V At 4 to 20 mA

Initial situation:

- Transducer with magnet within measuring range



Activate teach-in

- ▶ Press **1** for at least 4 s.



Set null point

- ▶ Bring magnet to the new null point.

- ▶ Press **1** for at least 2 s.

⇒ The new null point is set once the button is released.

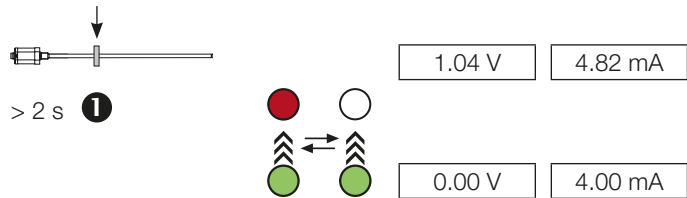

Set end point

- ▶ Bring magnet to the new end point.

- ▶ Press **2** for at least 2 s.

⇒ The new end point is set once the button is released.

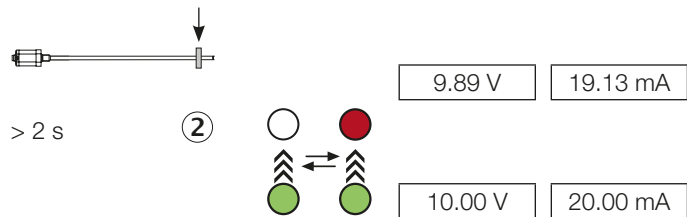

Invert curves

- ▶ Simultaneously press **1** and **2** for at least 4 s, until both LEDs are illuminated in red.

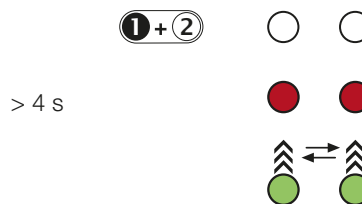

⇒ The curves of both outputs are inverted once the buttons are released.

End teach-in

- ▶ Briefly press **1** and **2** simultaneously (< 1 s).

⇒ The current position value is displayed once the buttons are released.

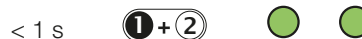

i Any of the individual steps for settings can be selected. The teach-in process can be ended at any time.

LED legend:		LED not on
		LED green
		LED red
		LED 1 and LED 2 flashing green-green in alternation

9

Adjust with the calibration device

NOTICE!

Interference in function

Adjustment while the system is running may result in malfunctions.

- ▶ Stop the system before performing adjustment.

LED display Displayed values (example)
 LED1 LED2 At 0 to 10 V At 4 to 20 mA

Initial situation:

- Transducer with magnet within measuring range

Activate adjusting

- ▶ Press **2** for at least 4 s.

Set start point

- ▶ Bring magnet to the new start point.
- ▶ Press **1** for at least 2 s.

⇒ The new start point is set with the last valid start value.

Adjust start value

- ▶ The start value can be changed using **1** and **2**¹⁾. The gradient of the curve changes (see page 18).

- ▶ End calibration procedure: Briefly press **1** and **2** simultaneously (< 1 s).
 ⇒ Set position value is saved.

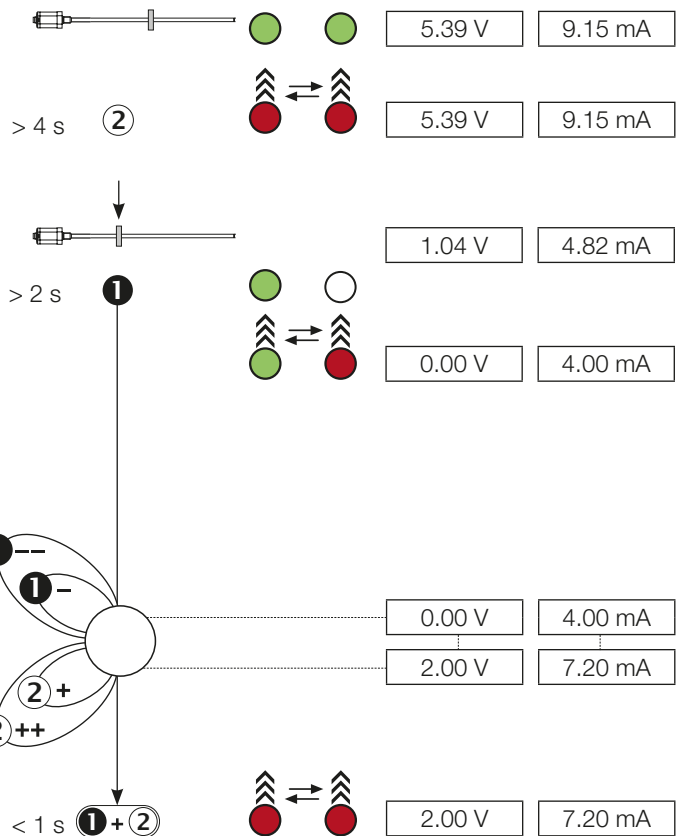

For setting the end point, adjusting the end value, and exiting adjustment, see page 21.

i Any of the individual steps for settings can be selected. The adjustment process can be ended at any time.

1) Briefly press button: Current value is increased or decreased by approx. 1 mV or 1 µA. If a button is held down longer than 1 s, the step interval is increased.

LED legend:

- LED not on
- LED green
- ⬆️⬆️ LED 1 and LED 2 flashing green-red in alternation
- ⬆️⬆️ LED 1 and LED 2 flashing red-red in alternation

9

Adjust with the calibration device (continued)

LED display Displayed values (example)
 LED1 LED2 At 0 to 10 V At 4 to 20 mA

Set end point

- ▶ Bring magnet to the new end point.
- ▶ Press **2** for at least 2 s.
- ⇒ The new end point is set with the last valid end value.

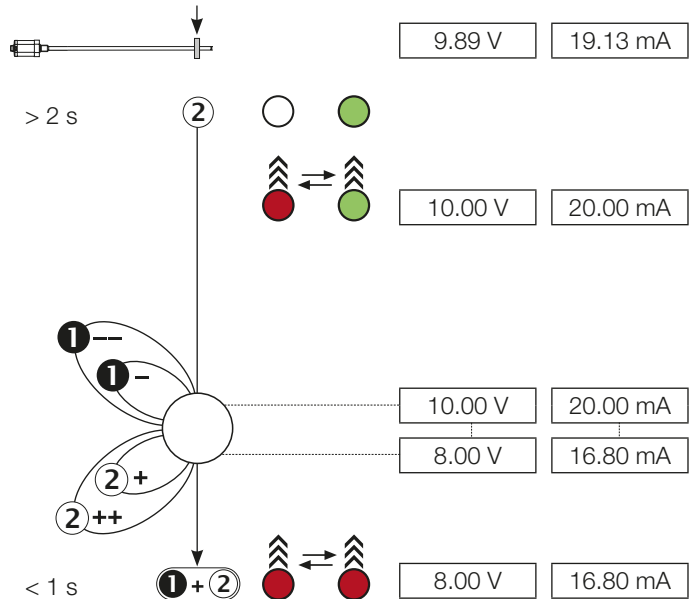

Adjust end value

- ▶ The end value can be changed using **1** and **2**¹⁾. The gradient of the curve changes (see page 18).
- ▶ End calibration procedure: Briefly press **1** and **2** simultaneously (< 1 s).
- ⇒ Set position value is saved.

End adjustment

- ▶ Briefly press **1** and **2** simultaneously (< 1 s).
- ⇒ The current position value is displayed once the buttons are released.

i Any of the individual steps for settings can be selected. The adjustment process can be ended at any time.

1) Briefly press button: Current value is increased or decreased by approx. 1 mV or 1 µA. If a button is held down longer than 1 s, the step interval is increased.

LED legend:	○ LED not on		LED 1 and LED 2 flashing red-green in alternation
	● LED green		LED 1 and LED 2 flashing red-red in alternation

9

Adjust with the calibration device (continued)

Switch the output to be adjusted (optional)

i As standard, the values are adjusted at output 1 and the values at output 2 are inverted accordingly.
 From serial number 100503000xxxxx xx, it is possible to optionally switch adjustment from output 1 to output 2.

LED display Displayed values (example)
 LED1 LED2 At 0 to 10 V At 4 to 20 mA

Initial situation:

– Transducer with magnet within measuring range



Activate adjusting

▶ Press ② for at least 4 s.



Switch the output to be adjusted

▶ Press ① and ② for at least 4 s, until one LED flashes green.

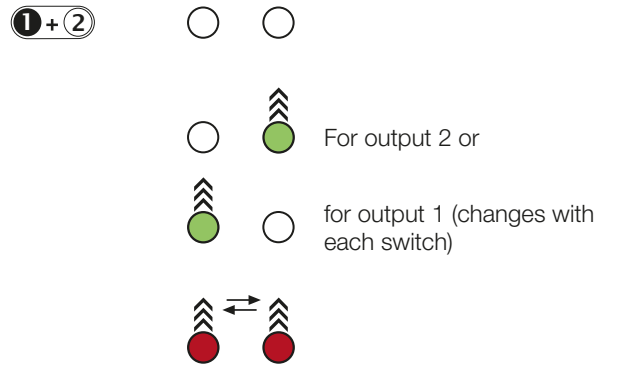

⇒ Both LEDs will flash again once the buttons are released.

▶ Continue with Set start point (see page 20).

LED legend:

- LED not on
- LED green
- ⤴ LED flashing green
- ⤴⤵ LED 1 and LED 2 flashing red-red in alternation

10 Reset all values with the calibration device (reset)

NOTICE!

Interference in function

Resetting all values while the system is running may result in malfunctions.

- ▶ Stop the system before performing the reset.

The reset function can be used to restore all the settings to the factory settings. For a reset the magnet may also be located outside the measuring range.

LED display

LED1 LED2

Activate reset

- ▶ Simultaneously press ① and ② for at least 4 s.
- ▶ Release buttons.
- ⇒ Reset is activated.

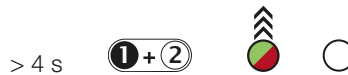

Reset

- ▶ Press ① and ② for at least 4 s.
- ▶ Release buttons.
- ⇒ All values are reset.
- ⇒ Current position value is displayed.
- ⇒ Reset is deactivated.

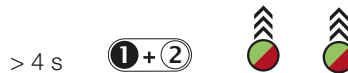

Abort reset

i Resetting can be aborted without any changes being saved after the Activate reset step.

- ▶ Briefly press ① and ② simultaneously (< 1 s).
- ▶ Release buttons.
- ⇒ Current position value is displayed.



1 1 Technical data

11.1 Accuracy

The specifications are typical values for the BTL7-A/E... at 24 V DC and room temperature, with a nominal length of 500 mm in conjunction with the BTL-P-1013-4R, BTL-P-1013-4S, BTL-P-1012-4R or BTL-P-1014-2R magnet.

The BTL is fully operational immediately, with full accuracy after warm-up.

i For special versions, other technical data may apply.
 Special versions are indicated by the suffix -SA on the part label.

Repeat accuracy	
Voltage, typical	±10 µm
Current, typical	±5 µm
Sampling rate	
With one magnet:	
Dependent on the nominal length	250 µs ¹⁾ to 5.7 ms
At nominal length = 500 mm	500 µs
With two magnets:	
Dependent on the nominal length	375 µs ¹⁾ to 8.55 ms
At nominal length = 500 mm	750 µs
Non-linearity at	
Nominal length ≤ 500 mm	±50 µm
Nominal length > 500 to ≤ 5500 mm	±0.01% FS
Nominal length > 5500 mm	±0.02% FS
Temperature coefficient ²⁾	≤ 30 ppm/K
Max. detectable velocity	10 m/s

11.2 Ambient conditions³⁾

Operating temperature	-40°C to +85°C
Operating temperature for UL (only BTL7-...-KA...)	Max. +80 °C
Storage temperature	-40°C to +100°C
Relative humidity	< 90%, non-condensing
Rod pressure rating (when installed in hydraulic cylinders)	
For Ø 8 mm	≤ 250 bar
For Ø 10.2 mm	≤ 600 bar
Shock rating per EN 60068-2-27 ⁴⁾	150 g/6 ms
Continuous shock per EN 60068-2-29 ⁴⁾	150 g/2 ms
Vibration per EN 60068-2-6 ⁴⁾ (note resonant frequency of the rod)	20 g, 10 to 2000 Hz
Degree of protection per IEC 60529	
Connector (when attached)	IP 67
Cable	IP 68 ⁴⁾

11.3 Supply voltage (external)

Voltage, stabilized ⁵⁾	10 to 30 V DC
Ripple	≤ 0.5 V _{ss}
Current draw (at 24 V DC)	
BTL7-A501-...	≤ 150 mA
BTL7-E501-...	≤ 180 mA
Inrush current	≤ 500 mA/10 ms
Reverse polarity protection ⁶⁾	Up to 36 V
Overvoltage protection	Up to 36 V
Dielectric strength (GND to housing)	500 V AC

11.4 Output

BTL7-A501	
Output voltage	
Max. configuration ⁷⁾	-10 to 10 V / 10 to -10 V
Factory setting	0 to 10 V / 10 to 0 V
Load current	≤ 5 mA
BTL7-E501	
Output current	
Max. configuration ⁷⁾	0 to 20 mA / 20 to 0 mA
Factory setting	4 to 20 mA / 20 to 4 mA
Load resistance	≤ 500 ohms
Short circuit resistance	Signal cable to 36 V Signal cable to GND

11.5 Communication lines La, Lb

Short circuit resistance	Signal cable to GND
--------------------------	---------------------

¹⁾ Only position output. For velocity output, next-higher measured value rate (500 µs or 750 µs).

²⁾ Nominal length = 500 mm, magnet in the middle of the measuring range

³⁾ For : Use in enclosed spaces and up to a height of 2000 m above sea level.

⁴⁾ Individual specifications as per Balluff factory standard

⁵⁾ For : The transducer must be externally connected via a limited energy circuit as defined in UL 61010-1, a low-power source as defined in UL 60950-1, or a class 2 power supply as defined in UL 1310 or UL 1585.

⁶⁾ A prerequisite is that no current can flow between GND and 0 V in the event of polarity reversal.

⁷⁾ Only with PC software (Configuration Tool)

BTL7-A/E501-M___-A/B/Y/Z(8)-S32/S115/S140/KA___/FA___ Micropulse Transducer - Rod Style

11

Technical data (continued)

11.6 Dimensions, weights

Diameter of rod	8 mm or 10.2 mm
Nominal length	
For Ø 8 mm	25 to 1016 mm
For Ø 10.2 mm	25 to 7620 mm
Weight (depends on length)	Approx. 2 kg/m
Housing material	Anodized aluminum
Rod material	Stainless steel 1.4571
Rod wall thickness	
For Ø 8 mm	0.9 mm
For Ø 10.2 mm	2 mm
Young's modulus	Approx. 200 kN/mm ²
Housing mounting via threads	M18×1.5 or 3/4"-16UNF
Tightening torque	Max. 100 Nm

BTL7-...-KA___

Cable material	PUR cULus 20549 80°C, 300 V, internal wiring
Cable temperature	-40°C to +90°C
Cable diameter	Max. 7 mm
Permissible bending radius	
Fixed routing	≥ 35 mm
Movable	≥ 105 mm

BTL7-...-FA___

Cable material	PTFE No UL approval available
Cable temperature	-55°C to +200°C
Cable diameter	Max. 7 mm
Permissible bending radius	
Fixed routing	≥ 35 mm
Movable	No permissible bending radius

12 Accessories

Accessories are not included in the scope of delivery and must be ordered separately.

12.1 Magnets

BTL-P-1013-4R

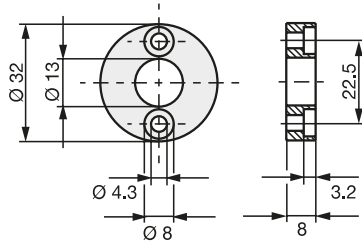

BTL-P-1013-4S

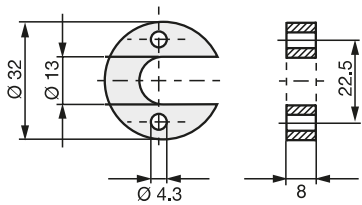

BTL-P-1012-4R

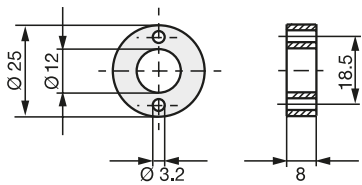

BTL-P-1014-2R

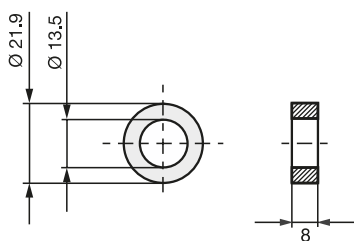

Fig. 12-1: Magnet installation dimensions

BTL-P-1013-4R, BTL-P-1013-4S, BTL-P-1012-4R, BTL-P-1014-2R:

Weight: Approx. 10 g
 Housing: Anodized aluminum

Included in the scope of delivery for the BTL-P-1013-4R, BTL-P-1013-4S, BTL-P-1012-4R:

Spacer: 8 mm, material: polyoxymethylene (POM)

BTL5-P-4500-1 magnet (solenoid):

Weight: Approx. 90 g
 Housing: Plastic
 Operating temperature: -40°C to +60°C

BTL-P-1028-15R (special accessories for applications with a supporting rod):

Weight: Approx. 68 g
 Housing: Anodized aluminum

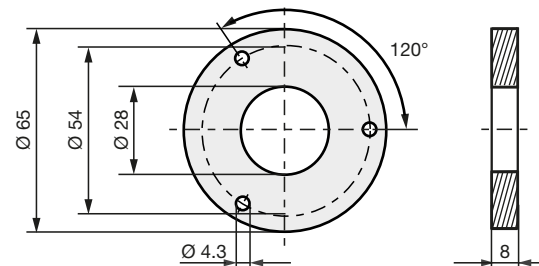

Fig. 12-2: Special accessories BTL-P-1028-15R

12.2 Mounting nut

- M18×1.5 mounting nut:
 BTL-A-FK01-E-M18×1.5
- Mounting nut 3/4"-16UNF:
 BTL-A-FK01-E-3/4"-16UNF

12 Accessories (continued)

12.3 Connectors and cables

12.3.1 BKS-S32/S33M-00, freely configurable

BKS-S32M-00

Straight connector, freely configurable
 M16 per IEC 130-9, 8-pin

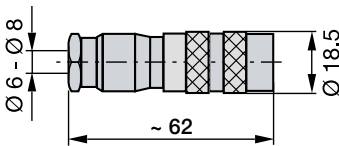

Fig. 12-3: Connector BKS-S32M-00

BKS-S33M-00

Angled connector, freely configurable
 M16 per IEC 130-9, 8-pin

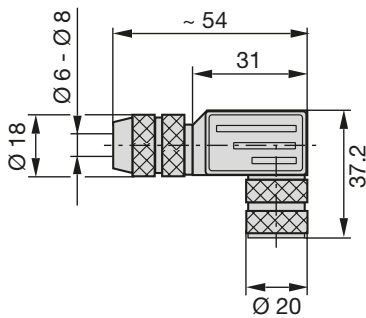

Fig. 12-4: Connector BKS-S33M-00

12.3.2 BKS-S232/S233-PU-___, preassembled

BKS-S232-PU-___

Straight connector, molded, preassembled
 M16, 8-pin
 Various cable lengths can be ordered, e.g.
 BKS-S232-PU-05: Cable length 5 m

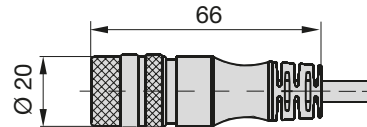

Fig. 12-5: Connector BKS-S232-PU-___

BKS-S233-PU-___

Angled connector, molded, preassembled
 M16, 8-pin
 Various cable lengths can be ordered, e.g.
 BKS-S233-PU-05: Cable length 5 m

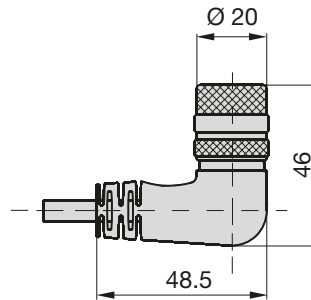

Fig. 12-6: Connector BKS-S233-PU-___

i The outlet direction and the pin assignment for the BKS-S233-PU-___ is the same as that for the BKS S116-PU-___ (see Fig. 12-9 or Tab. 12-1).

12 Accessories (continued)

12.3.3 BKS-S115/S116-PU-___, preassembled

BKS-S115-PU-___

Straight connector, molded-on cable, preassembled
 M12, 8-pin
 Various cable lengths can be ordered, e.g.
 BKS-S115-PU-05: Cable length 5 m

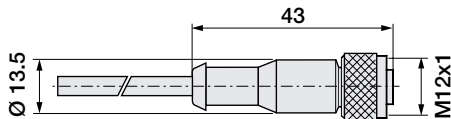

Fig. 12-7: Connector BKS-S115-PU-___

BKS-S116-PU-___

Angled connector, molded-on cable, preassembled
 M12, 8-pin
 Various cable lengths can be ordered, e.g.
 BKS-S116-PU-05: Cable length 5 m

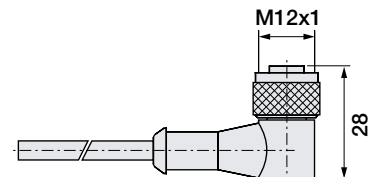

Fig. 12-8: Connector BKS-S116-PU-___

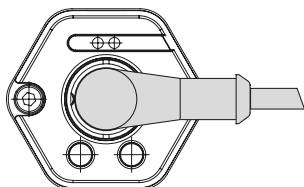

Fig. 12-9: Connector BKS-S116-PU-___, outlet

Pin	Color
1	YE yellow
2	GY gray
3	PK pink
4	RD red
5	GN green
6	BU blue
7	BN brown
8	WH white

Tab. 12-1: BKS-S115/S116-PU-___ pin assignment

12.3.4 BKS-S140-23-00, freely configurable

BKS-S140-23-00

Straight connector, freely configurable
 10-pin

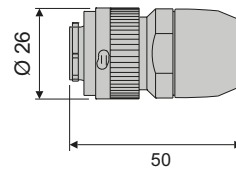

Fig. 12-10: Connector BKS-S140-23-00

12.3.5 Plug-in system, 8-pin

The transducer is available with an 8-pin pigtail plug-in system. The plug-in system has two parts:

- The M12 contact insert is preassembled to the transducer's cable
- The square flange for assembly using the contact insert is included in the scope of delivery.

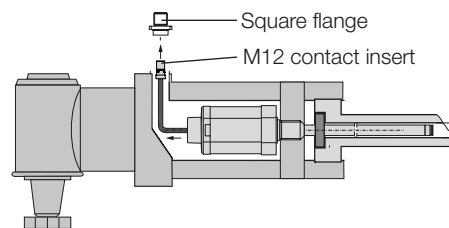

Fig. 12-11: Plug-in system based on the example installing the transducer in a hydraulic cylinder

Series ZA10

Square flange material: Nickel-plated brass
 BTL7-...-KA00,2-ZA10, PUR cable 0,2 m
 BTL7-...-KA00,3-ZA10, PUR cable 0,3 m

Series ZA15

Square flange material: Stainless steel 1.4404
 BTL7-...-KA00,2-ZA15, PUR cable 0,2 m
 BTL7-...-KA00,3-ZA15, PUR cable 0,3 m

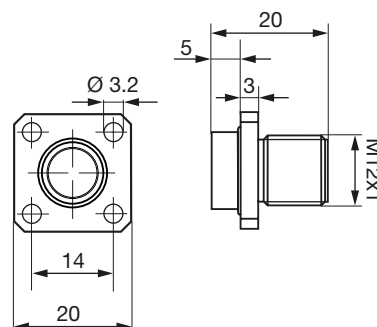

Fig. 12-12: Square flange

12

Accessories (continued)

12.4 USB communication box

BTL7-A-CB01-USB-S32

For BTL7-A/E501-... with S32 connector.

Scope of delivery: USB communication box, USB cable,
2 adapter cables each approx. 0.3 m, condensed guide.

BTL7-A-CB01-USB-S115

For BTL7-A/E501-... with S115 connector.

Scope of delivery: USB communication box, USB cable,
2 adapter cables each approx. 0.3 m, condensed guide.

BTL7-A-CB01-USB-S140

For BTL7-A/E501-... with S140 connector.

Scope of delivery: USB communication box, USB cable,
2 adapter cables each approx. 0.3 m, condensed guide.

BTL7-A-CB01-USB-KA

For BTL7-A/E501-... with cable connection

Scope of delivery: USB communication box, USB cable,
1 adapter cable approx. 0.6 m, condensed guide.

**BTL7-A/E501-M____-A/B/Y/Z(8)-S32/S115/S140/KA_/FA_
Micropulse Transducer - Rod Style**

13 Type code breakdown

BTL7 - A 5 0 1 - M0500 - B - S32

Micropulse transducer

Interface:

A = Analog interface, voltage output 0 to 10 V (Factory setting)

E = Analog interface, current output 4 to 20 mA (Factory setting)

Supply voltage:

5 = 10 to 30 V DC

Output gradient:

01 = 2 outputs, configurable

Nominal stroke (4-digit):

M0500 = Metric specification in mm, nominal length 500 mm

(M0025 to M1016: A8, B8, Y8, Z8)

(M0025 to M7620: A, B, Y, Z)

Rod version, fastening:

A = Metric mounting thread M18x1.5, rod diameter 10.2 mm

B = Metric mounting thread M18x1.5, O-ring, rod diameter 10.2 mm

Y = 3/4"-16UNF thread, rod diameter 10.2 mm

Z = 3/4"-16UNF thread, O-ring, rod diameter 10.2 mm

A8 = Metric mounting thread M18x1.5, rod diameter 8 mm

B8 = Metric mounting thread M18x1.5, O-ring, rod diameter 8 mm

Y8 = 3/4"-16UNF thread, rod diameter 8 mm

Z8 = 3/4"-16UNF thread, O-ring, rod diameter 8 mm

Electrical connection:

S32 = 8-pin, M16 plug per IEC 130-9

S115 = 8-pin, M12 plug

S140 = 10-pin, plug

KA05 = Cable, 5 m (PUR)

FA05 = Cable, 5m (PTFE)

BTL7-A/E501-M___-A/B/Y/Z(8)-S32/S115/S140/KA___/FA___ Micropulse Transducer - Rod Style

14 Appendix

14.1 Converting units of length

1 mm = 0.0393700787 inch

mm	inches
1	0.03937008
2	0.07874016
3	0.11811024
4	0.15748031
5	0.19685039
6	0.23622047
7	0.27559055
8	0.31496063
9	0.35433071
10	0.393700787

Tab. 14-1: Conversion table mm to inches

1 inch = 25.4 mm

inches	mm
1	25.4
2	50.8
3	76.2
4	101.6
5	127
6	152.4
7	177.8
8	203.2
9	228.6
10	254

Tab. 14-2: Conversion table inches to mm

14.2 Part labels



¹⁾ Ordering code

²⁾ Type

³⁾ Serial number

Fig. 14-1: BTL7 part label

 **www.balluff.com**

Headquarters

Germany

Balluff GmbH
Schurwaldstrasse 9
73765 Neuhausen a.d.F.
Phone + 49 7158 173-0
Fax +49 7158 5010
balluff@balluff.de

Global Service Center

Germany

Balluff GmbH
Schurwaldstrasse 9
73765 Neuhausen a.d.F.
Phone +49 7158 173-370
Fax +49 7158 173-691
service@balluff.de

US Service Center

USA

Balluff Inc.
8125 Holton Drive
Florence, KY 41042
Phone (859) 727-2200
Toll-free 1-800-543-8390
Fax (859) 727-4823
technicalsupport@balluff.com

CN Service Center

China

Balluff (Shanghai) trading Co., Ltd.
Room 1006, Pujian Rd. 145.
Shanghai, 200127, P.R. China
Phone +86 (21) 5089 9970
Fax +86 (21) 5089 9975
service@balluff.com.cn