

# Klappschwimmerschalter

## Broken finger switches

### Détecteurs horizontaux

205 KS .20

Klappschwimmerschalter mit Tefloneugen  
Broken finger switches with teflon hinge  
Détecteurs horizontaux avec lamelle de téflon

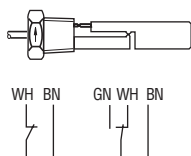
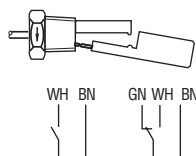
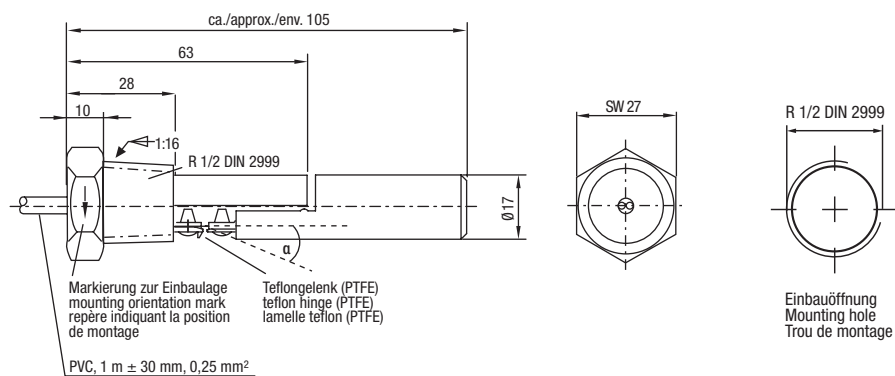

Typen Nr. type no. référence	Schaltspannung switching voltage tension de commutation	Schaltstrom switching current courant de commutation	Schaltleistung switching power pouvoir de coupure
205 KS 120	max. 250 V	max. 1,0 A	max. 50 W / 50 VA
205 KS 220	max. 48 V	max. 0,25 A	max. 3 W / 3 VA

Typen Nr. type no. référence	Schutzart protection class protection	Kontaktform contact form type de contact	Temperaturbereich temperature range plage de température	Material material matériaux
205 KS 120	IP 67	Schließer / N.O. / NO od./or/ou Öffner / N.C. / NF	-25...+105°C	PP/PTFE
205 KS 220		Wechsler / C.O. / inverseur		