

NI22U-Q40-AP6X2-H1141

Inductive sensor – For parts position control in die press tools

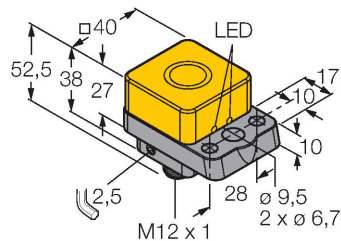

Features

- Rectangular, height 38 mm
- Active face on top
- Plastic, PBT-GF30-V0
- Factor 1 for all metals
- Resistant to magnetic fields
- Extended temperature range
- DC 3-wire, 10...30 VDC
- NO contact, PNP output
- M12 x 1 male connector

Wiring diagram

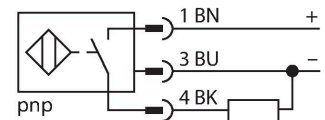

Functional principle

The Q40 series is specially designed for position control of pieces in large pressing tools. The height of the sensor can be altered with the screw. Recessed mounting protects the sensor against mechanical damage.

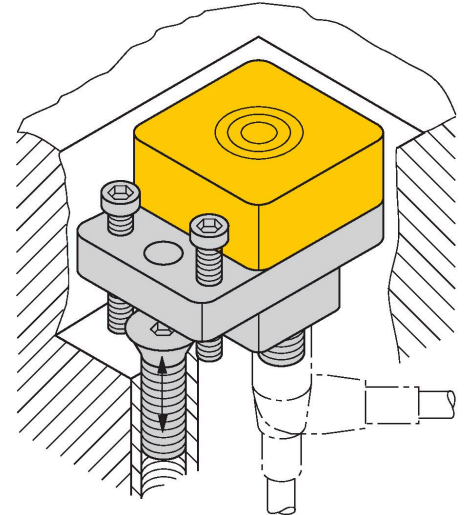

Technical data

Type	NI22U-Q40-AP6X2-H1141
Ident. no.	4690229
Rated switching distance	22 mm
Mounting conditions	Non-flush, recessible in press tool
Secured operating distance	$\leq (0.81 \times S_n)$ mm
Repeat accuracy	$\leq 2\%$ of full scale
Temperature drift	$\leq \pm 10\%$
Hysteresis	3...15 %
Ambient temperature	0...+70 °C
Operating voltage	10...30 VDC
Residual ripple	$\leq 10\% U_s$
DC rated operational current	≤ 200 mA
No-load current	≤ 15 mA
Residual current	≤ 0.1 mA
Isolation test voltage	≤ 0.5 kV
Short-circuit protection	yes / Cyclic
Voltage drop at I_e	≤ 1.8 V
Wire breakage/Reverse polarity protection	yes / Complete
Output function	3-wire, NO contact, PNP
Insulation class	□
Switching frequency	0.25 kHz
Design	Rectangular, Q40
Dimensions	67 x 40 x 52.5 mm
Housing material	Plastic, PBT-GF30-V0
Active area material	PBT-GF30-V0
Electrical connection	Connectors, M12 x 1
Vibration resistance	55 Hz (1 mm)

Technical data

Shock resistance	30 g (11 ms)
Protection class	IP68
MTTF	874 years acc. to SN 29500 (Ed. 99) 40 °C
Power-on indication	LED, Green
Switching state	LED, Yellow

Mounting instructions

Mounting instructions/Description

Distance D 240 mm

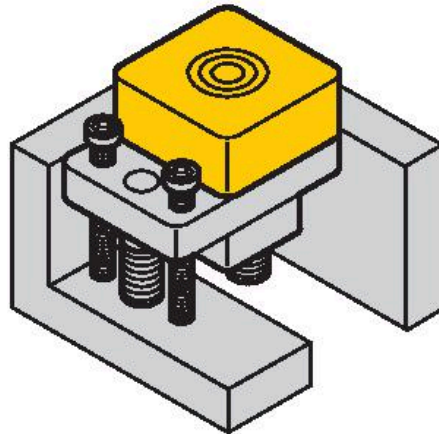
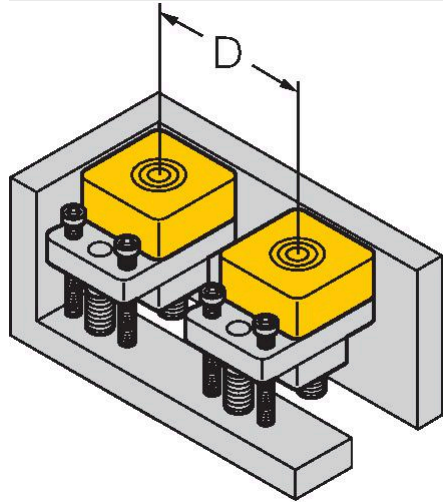

Non-flush mounting $S_r = 22$ mm
 Screw in the base such that the switching distance can be reduced to 10 mm.
 Recessed mounting $S_r = 19$ mm
 1 mm beneath the tool contour
 Screw in the base such that the switching distance can be reduced to 10 mm.
 Recessed mounting $S_r = 21$ mm
 11 mm beneath the tool contour
 Use the screws to modify the mounting depth.

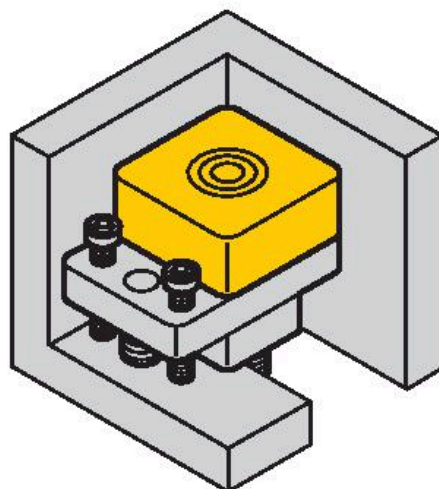
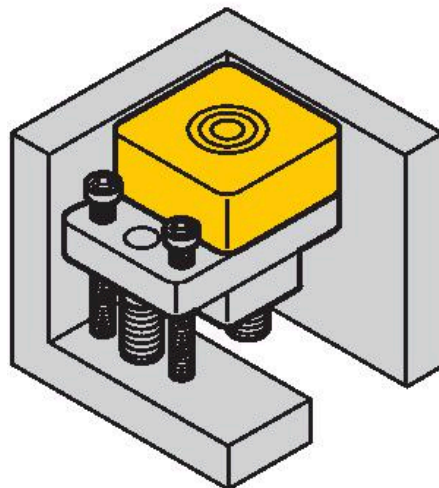

Accessories

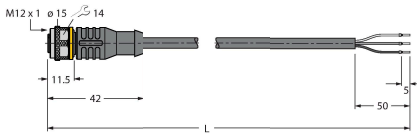
Dimension drawing	Type	Ident. no.	
	RKC4T-2/TEL	6625010	Connection cable, female M12, straight, 3-pin, cable length: 2 m, sheath material: PVC, black; cULus approval; other cable lengths and qualities available, see www.turck.com