

PT663024

LASER SENSORS • DISTANCE MEASUREMENT

Optical sensors function contactlessly. They detect objects independent of their characteristics (e.g., shape, color, surface structure, material). The basic operating principle is based on the transmission and reception of light. There are three different versions: 1. The through-beam sensor consists of two separate devices, a transmitter and a receiver that are aligned with one another. If the light beam between the two devices is interrupted, the switching output integrated in the receiver changes its status. 2. With the retro-reflective sensor, the transmitter and receiver are located in one device. The emitted light beam is reflected back to the receiver by a reflector that is to be mounted opposite the device. As soon as the light beam is interrupted, the switching output integrated in the device changes its status. 3. With the diffuse reflection sensor, the transmitter and receiver are in one device. The emitted light beam is reflected by the object that is to be detected. As soon as the receiver detects the reflected light, the switching output integrated in the device changes its status.



TECHNICAL DATA

Absolute linearity deviation	10 mm
Alarm output	Yes
Ambient temperature	0 °C ... 50 °C
Decay time	0.9 ms
Degree of protection (IP)	IP67
Geometrical resolution	2.5 mm
Housing design	Cuboid
Housing material	Zinc die-cast
Increased ambient temperatures >70°C	No
Laser protection class	Class 2
Light beam form	Line
Light source	Laser diode, red light
Light spot range	87.5 mm ²
Light spot range	21.25 mm ²
Light spot, laser focus	21.25 mm ²
Material of optical surface	Glass
Max. output current	100 mA
Measuring method for optical distance measurement	Triangulation
Measuring range length	200 mm ... 1000 mm
No-load current	100 mA
Number of pins	8
Reflector included in the scope of delivery	No
Relative linearity deviation	10 %
Resolution	2.5 mm
Response time	0.9 ms
Response/decay time	0.9 ms
Reverse polarity protection	Yes

TECHNICAL DATA

Scanning principle	Push button
Sensor height	65 mm
Sensor length	50 mm
Sensor width	20.6 mm
Setting procedure	Teach-In
Short-circuit-proof	Yes
Small light beam diameter	Yes
Supply voltage	12 V ... 28 V
Teach-in limits distance	20 mm
Type of alarm output	PNP
Type of analog output	0 V ... 10 V / 4 mA ... 20 mA
Type of electrical connection	Connector M12
Voltage type	DC
Wavelength of the sensor	650 nm
With LED display	Yes

CONNECTION

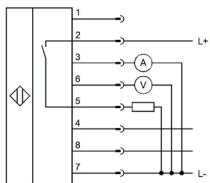

Colors: 1 = WH (white), 2 = BN (brown), 3 = GN (green), 4 = YE (yellow), 5 = GY (gray), 6 = PK (pink), 7 = BU (blue), 8 = RD (red)

Functions: 1 = n. c., 2 = L+, 3 = 4-20mA, 4 = teach-In, 5 = alarm, 6 = 0-10V, 7 = L-, 8 = sync.

DIMENSIONAL DRAWING

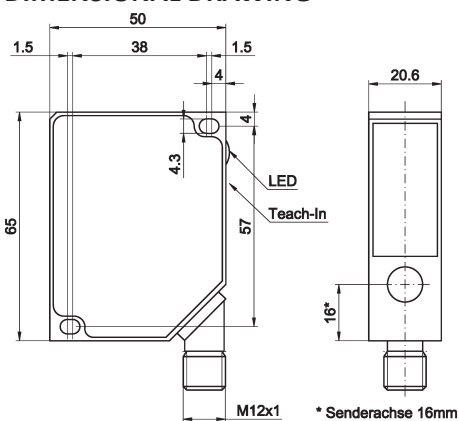

INSTALLATION



Mounting / Installation may only be carried out by a qualified electrician!

DISPOSAL



SAFETY WARNINGS

Before initial operation, please make sure to follow all safety instructions that may be provided in the product information!

Never use these devices in applications where the safety of a person depends on their functionality.