

Ultrasonic Diffuse, Digital Output Types UA18CAD.....TI

CARLO GAVAZZI



- Cylindrical M18 PBT housing
- Sensing distance: 50-2200 mm
- Power supply: 15 to 30 VDC
- Outputs: Two multi function switching outputs. PNP or NPN
- Setup: Normal switching or adjustable hysteresis
- Repeatability 0.5%
- Beam angle. $\pm 7^\circ$ or $\pm 8^\circ$
- Protection: Short-circuit, reverse polarity and overvoltage
- Protection degree IP 67
- 2 m cable or M12 plug

Product Description

A self-contained multi function diffuse ultrasonic sensor with a sensing range of 50 to 2200 mm in three ranges. 2 switching outputs - easily set up for two different output modes and adjusted by teach-in - makes it ideal for level control tasks in a wide variety of vessels. A sturdy

one-piece polyester housing provides the perfect packaging for the sophisticated microprocessor controlled and digitally filtered sensor electronics. Excellent EMC performance and precision are typical features of this sensor on true distance measurement.

Ordering Key

UA18CAD04NPM1TI

Ultrasonic sensor	_____
Housing style	_____
Housing size	_____
Housing material	_____
Housing length	_____
Detection principle	_____
Sensing distance	_____
Output type	_____
Output configuration	_____
Connection	_____
Teach-in	_____

Type Selection

Housing diameter	Connection	Rated operating dist. (S _n)	Digital output NPN/PNP	Ordering no.
M18	Plug M12	50-400 mm	2 x NPN	UA 18 CAD 04 NP M1 TI
M18	Cable	50-400 mm	2 x NPN	UA 18 CAD 04 NP TI
M18	Plug M12	50-400 mm	2 x PNP	UA 18 CAD 04 PP M1 TI
M18	Cable	50-400 mm	2 x PNP	UA 18 CAD 04 PP TI
M18	Plug M12	100-900 mm	2 x NPN	UA 18 CAD 09 NP M1 TI
M18	Cable	100-900 mm	2 x NPN	UA 18 CAD 09 NP TI
M18	Plug M12	100-900 mm	2 x PNP	UA 18 CAD 09 PP M1 TI
M18	Cable	100-900 mm	2 x PNP	UA 18 CAD 09 PP TI
M18	Plug M12	200-2200 mm	2 x NPN	UA 18 CAD 22 NP M1 TI
M18	Cable	200-2200 mm	2 x NPN	UA 18 CAD 22 NP TI
M18	Plug M12	200-2200 mm	2 x PNP	UA 18 CAD 22 PP M1 TI
M18	Cable	200-2200 mm	2 x PNP	UA 18 CAD 22 PP TI

Specifications

Rated operating distance (S _n)	Reference target: 1 mm metal rolled finish. CAD04: 100 x 100 mm CAD09 and CAD22: 200 x 200 mm 50 - 400 mm 100 - 900 mm 200 - 2200 mm	Repeatability	0.5%
UA18CAD04 UA18CAD09 UA18CAD22		Beam angle UA18CAD04... UA18CAD09... UA18CAD22...	$\pm 8^\circ$ $\pm 7^\circ$ $\pm 7^\circ$
Blind zone UA18CAD04... UA18CAD09... UA18CAD22...	≤ 50 mm ≤ 100 mm ≤ 200 mm	Adjustment Push-button	P1 (farthest setpoint) P2 (nearest setpoint)
		Temperature drift	$\leq 0.1\%/^\circ\text{C}$ @ -20° to $+60^\circ\text{C}$
		Temperature compensation	Yes

Specifications (cont.)

Hysteresis (H)	Min. 1%	Normal Switching function with N.O. output. Adjustable hysteresis Filling or emptying control
Rated operational voltage (U_B)	15 to 30 VDC (ripple included)	
Ripple (U_{rip})	≤ 5%	
No-load supply current (I_o)		Indication Output ON
UA18CAD04...	≤ 45 mA @ U_B max	Yellow LED
UA18CAD09...	≤ 45 mA @ U_B max	Environment
UA18CAD22...	≤ 50 mA @ U_B max	Installation category
Output current continuous (I_o)		Pollution degree
Max. load capacity 100 nF	≤ 500 mA	Degree of protection
UL508 specification	≤ 100 mA	Ambient temperature
Output current short-time (I)		Operating
Max. load capacity 100 nF	≤ 500 mA	Storage
UL508 specification	≤ 100 mA	Vibration
Minimum operational current (I_m)	≤ 0.5 mA	10 to 55 Hz, 1.0 mm/6g (IEC/EN 60068-2-6)
OFF-state current (I_r)	≤ 10 μ A	Shock
Voltage drop (U_d)	≤ 2.2 VDC @ I_o max.	30 g / 11 mS, 3 directions (IEC/EN 60068-2-27)
Protection	Short-circuit, overvoltage and reverse polarity	Rated insulation voltage
Carrier frequency		< 500 VAC (rms)
UA18CAD04...	400 kHz	Housing
UA18CAD09...	300 kHz	Material body
UA18CAD22...	200 kHz	Material front
Operating frequency (f)		Material back, plug
UA18CAD04...	≤ 10 Hz	Material back, cable
UA18CAD09...	≤ 4 Hz	Material push-button
UA18CAD22...	≤ 1 Hz	Sealing around push-button
Response time OFF-ON (t_{ON})		Material sealing front
UA18CAD04...	≤ 50 mS	UA18CAD04...
UA18CAD09...	≤ 125 mS	UA18CAD09...
UA18CAD22...	≤ 500 mS	UA18CAD22...
Response time ON-OFF (t_{OFF})		Connection
UA18CAD04...	≤ 50 mS	Cable
UA18CAD09...	≤ 125 mS	PVC, grey, 2 m, 4 x 0.32 mm ² , $\varnothing = 4.7$
UA18CAD22...	≤ 500 mS	mm
Power ON delay	≤ 900 mS	Plug
Output function, open collector		M12, 4-pin (CON. 14-series)
By sensor type	NPN or PNP	Tightening torque
Output switching function	Two open collector transistor outputs to be configured as:	≤ 1 Nm
		Weight
		Cable version
		Plug version
		CE-marking
		Yes
		Approvals
		cULus (UL508)

Wiring Diagram

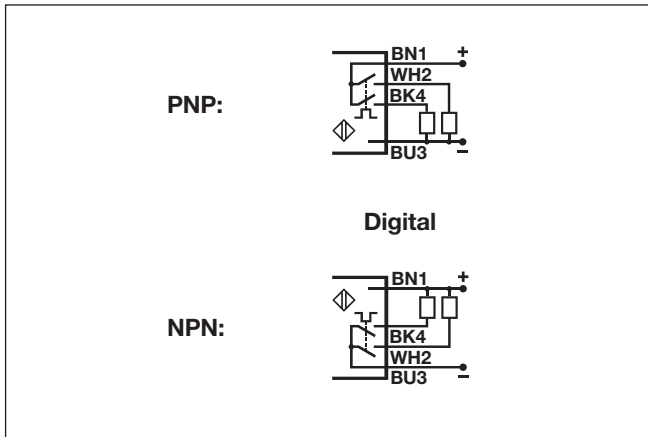

Detection Range

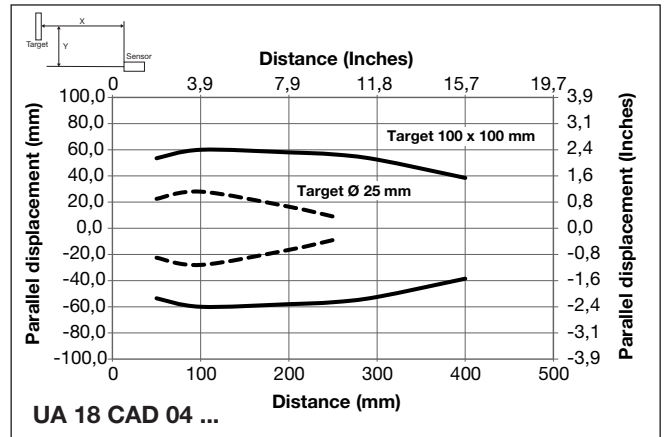

Dimensions

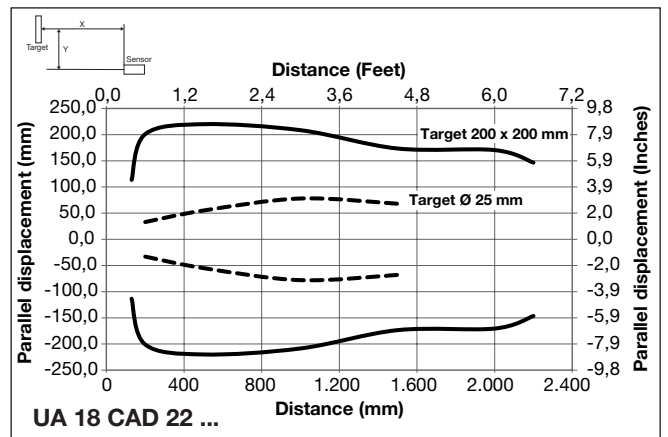
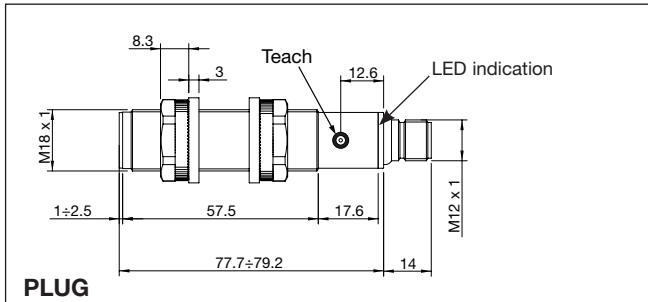
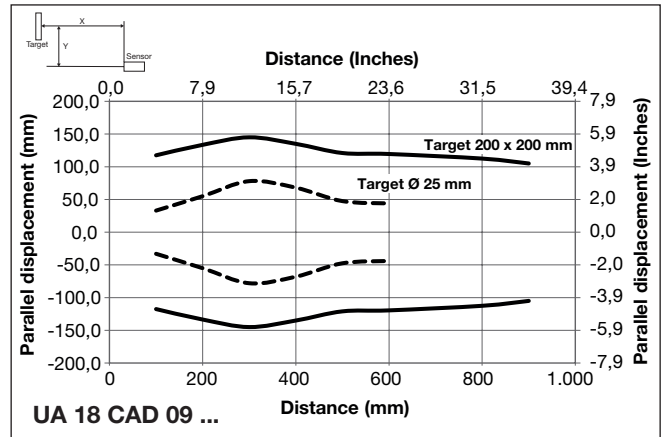
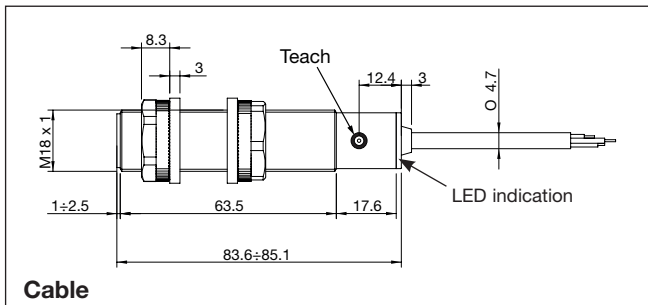

Programming setup

General set up of sensing point P1 (longest distance) and P2 (shortest distance) independently of the sensor type or function.

- 1) Mount the sensor in the selected application.
- 2) Place a target in front of the sensor at the maximum required distance (P1), then press shortly on the teach-button. The yellow LED switches Off and then On again after a maximum of 2 seconds. Now, the distance (P1) is saved in the sensor, and the target can be moved. I)
- 3) Place the target at the minimum distance requested (P2), then press shortly on the teach-button. The yellow LED turns Off and then flashes 5 times. Now, the distance (P2) is saved in the sensor and the target can be moved. II)

I) P1 can be set to maximum exceeding the family specification for the sensor by removing the target in front of the sensor. Push and hold the teach-button for more than one second and the sensing distance is set at a unique distance for this sensor only.

II) The second switch point can be set to minimum by setting the target within the blind zone close to the sensor head or by covering the sensor head with your hand while teaching P2.

Sensors with 2 digital outputs: UA..CAD..PP/NP types, Normal sensing function or Adjustable Hysteresis

- 1) The factory settings are normal sensing function.

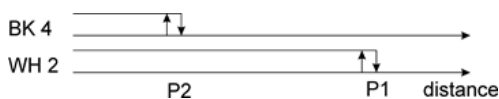

- 2) Push and hold the teach-button for 8 seconds (12 for UC18CAD22..) until the yellow LED flashes fast, then release the teach-button and the LED will flash 5 times to acknowledge the change in function. Now, the sensor is in adjustable hysteresis mode.

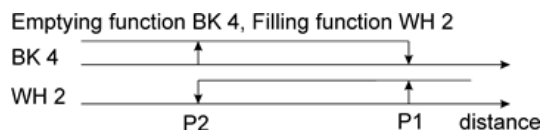

- 3) To switch back to normal function, repeat step 2.

Installation Hints

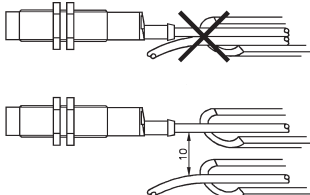
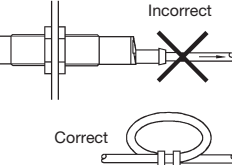
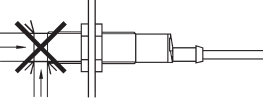
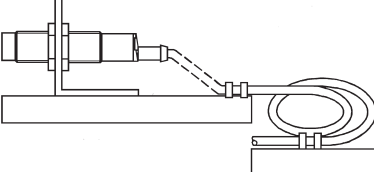
<p><i>To avoid interference from inductive voltage/current peaks, separate the prox. switch power cables from any other power cables, e.g. motor, contactor or solenoid cables</i></p> 	<p><i>Relief of cable strain</i></p>  <p>Incorrect</p> <p>Correct</p> <p>The cable should not be pulled</p>	<p><i>Protection of the sensing face</i></p>  <p>A proximity switch should not serve as mechanical stop</p>	<p><i>Switch mounted on mobile carrier</i></p>  <p>Any repetitive flexing of the cable should be avoided</p>
--	--	--	---

Delivery Contents

- Ultrasonic sensor: UA18CAD....
- Installation instruction
- Mounting:
 - 2 x M18 Nuts
 - 2 x rubber washers
- **Packaging:** Carton box 35 x 107 x 173 mm

Mouser Electronics

Authorized Distributor

Click to View Pricing, Inventory, Delivery & Lifecycle Information:

[Carlo Gavazzi:](#)

[UA18CAD09PPTI](#) [UA18CAD22NPTI](#) [UA18CAD09PPM1TI](#) [UA18CAD04PPM1TI](#) [UA18CAD22PPTI](#)
[UA18CAD09NPTI](#) [UA18CAD22NPM1TI](#) [UA18CAD09NPM1TI](#) [UA18CAD04PPTI](#) [UA18CAD04NPTI](#)
[UA18CAD22PPM1TI](#) [UA18CAD04NPM1TI](#)